

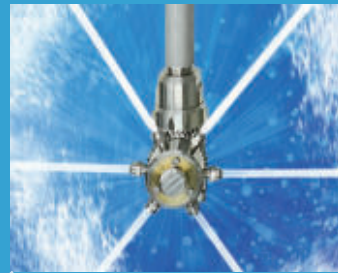

IKEUCHI TANK CLEANING NOZZLE CATALOG



THE FOG ENGINEERS
IKEUCHI

Automated tank cleaning solutions— spray nozzles from IKEUCHI.

Still cleaning production tanks and equipment by hand?

Save time and money with tank cleaning nozzles from IKEUCHI. Years of experience in a wide variety of industries and settings give IKEUCHI the expertise to propose the best plan for any situation, including additions to existing cleaning systems and automated cleaning in multi-line set-ups. Contact IKEUCHI with any questions regarding cleaning in place (CIP) and HACCP compliance.



Chemicals



Paper making



Ships



Ceramics



Food products



Pharmaceutical



Spinning



Nuclear energy

many
more

Scan the QR code on each product page for 3D/2D CAD drawings on PARTCommunity's website.
To view some products an account is required. Registration is free of charge.



The text QR Code itself is a registered trademark and wordmark of Denso Wave Incorporated.

https://ikeuchi.partcommunity.com/3d-cad-models/?languagealso=en&info=ikeuchi/metric_unit/tank_cleaner

Digital catalogs are available on our website.  [IKEUCHI digital catalog](#)

CONTENTS

Basic Information	3
Distribution Chart for Spray Flow Rate	5
Nozzle Selection Guide by Application	6
Case Studies	7

Cleaning Easy to Remove Dirt

● SR Series Low-speed Rotation, Wide Area Cleaning	9
● ES Series Metal / Self-cleaning, Easy Maintenance	12
● ES/ESV-PTFE Series Resistant to Chemicals	16

Cleaning Hard to Remove Dirt

RJ Series ROTARY JETTER

● RJ Series Powerful 3D Rotational Cleaning	19
● RJ3-MD Series with Air/Electric Motor for Powerful Cleaning	22

JA Series JET ATTACKER

● JA3 Series Powerful 3D Rotational Cleaning	25
● JA3-D180 Series 3D Rotation, 180° Downward Spray.....	28
● JA2 Series Powerful 2D Rotational Cleaning	31

Non-rotation Nozzle

● SWB Series SHOWER BALL	34
---------------------------------------	----

Duct Cleaning

● RJ2-PON Series Pressure-open Nozzle	36
--	----

Cleaning Tall Tanks

● Automatic Nozzle Lifting System	39
--	----

FAQ	41
------------------	----

Conversion of Units	42
----------------------------------	----

Basic Information

Spray Pattern

01

There are two different types of tank cleaning nozzles, based on their spray patterns: the "solid stream spray" nozzle which sprays the cleaning liquid in a straight single stream, and the "flat spray" nozzle with a flat fan shaped spray pattern.

In general, the solid stream spray nozzle is used for cleaning hard-to-remove and stubborn dirt, the flat spray nozzle is for cleaning dirt that is easily removable.

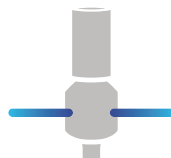

Solid stream spray nozzles

This nozzle sprays the cleaning liquid in a straight single stream.

- Use for:**
- Removing tough, sticky dirt
 - Cleaning off hard to remove dirt



Flat spray nozzles

This nozzle sprays the cleaning liquid in a flat fan shaped pattern.

- Use for:**
- Washing large surfaces quickly
 - Cleaning off dirt that is easily removable

Reach Distance of Spray

02

The reach distance of spray is the linear distance from the orifice of the nozzle to the point where the spray loses momentum and effectiveness. In other words, it represents not just how far the spray can reach, but the distance at which the spray force remains effective for cleaning.

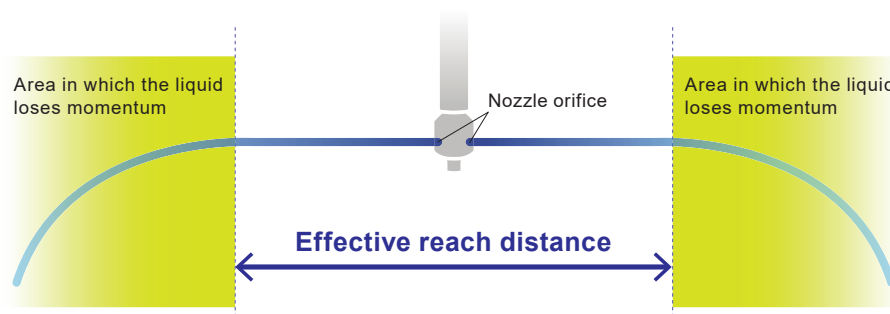

The illustration shows a solid stream spray nozzle. For the RJ series only, the effective cleaning distance extends beyond the regular reach distance and is given as radius measurement.

Nozzle Rotation

03

Tank cleaning nozzles are classified into three types, based on their rotation specifications: "3D Rotation" (three-dimensional rotation), "2D Rotation" (two-dimensional rotation), and "Fixed".



3D Rotation

Uses two rotary drives. Can clean while rotating 360 degrees. Strong cleaning power.

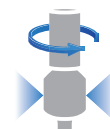

2D Rotation

Uses one rotary drive. Quick cleaning of a large area.



Fixed

No rotary drive or moving parts that can fail or cause wear debris and therefore less downtime for maintenance.

Clog Prevention (Strainer and Flushing the Piping)

Clogging can cause malfunction and damage to the product. Be sure to flush the pipe system thoroughly before installing the nozzle to remove dust and debris.

Regardless of the type of cleaning liquid, whether it is used once or can be reused multiple times, it should always run through a strainer to prevent the nozzle from clogging.

Refer to the table on the right for details.

Note: Depending on cleaning liquid type and quality, use a finer mesh strainer or install a filter cartridge to prevent deposits of foreign particles.

Series	Recommended mesh size for the strainer
SR	#200 or more
ES, ESV	#100 or more
RJ, RJ2-PON, JA	#50 or more
SWB	#40 or more

Contact us for custom-made models.

Nozzle Mounting Direction

In general, our tank cleaning nozzles are designed with the presumption that they are inserted and installed downward at the top of the tank.

Installing the nozzle sideways and upward at the side or bottom of the tank may result in distortion of the rotary shaft or faulty installation which may cause problems with the operation.

Some series, however, are designed so they can be installed in other directions, please refer to the table on the right.

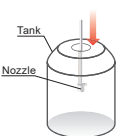
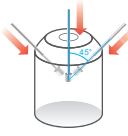
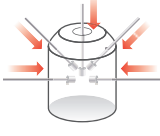
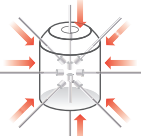
Series	Mounting direction	Series	Mounting direction
SR	 <p>Only install downward, from the top</p>	JA3, JA3-D180	 <p>Can be installed downward within 45° of the vertical center</p>
RJ	 <p>Can be installed downward or sideways (within 90° of the vertical center)</p>	ES, ESV, JA2	 <p>Can be installed in any direction 360°</p>

Note: The data in this catalog are the values from top of the tank installations.

Pre-Shipment Inspection

All of IKEUCHI's tank cleaning nozzles undergo the following inspections before being shipped, to ensure complete customer satisfaction.

Rotation

The rotation speed at the specified pressure is checked. The ES/ESV-PTFE series are checked for their smooth rotation since their rotation speed is too fast to measure.

Spray Flow Rate

The flow rate is checked if it meets IKEUCHI's spray capacity standard set for each series.

Distribution Chart for Spray Flow Rate

The performance level is not only determined by the operating pressure and spray flow rate. It is important to select a tank cleaning nozzle that matches your application and the conditions it is used in.

Distribution Chart for Each Nozzle Series

SR, ES, and ESV Series

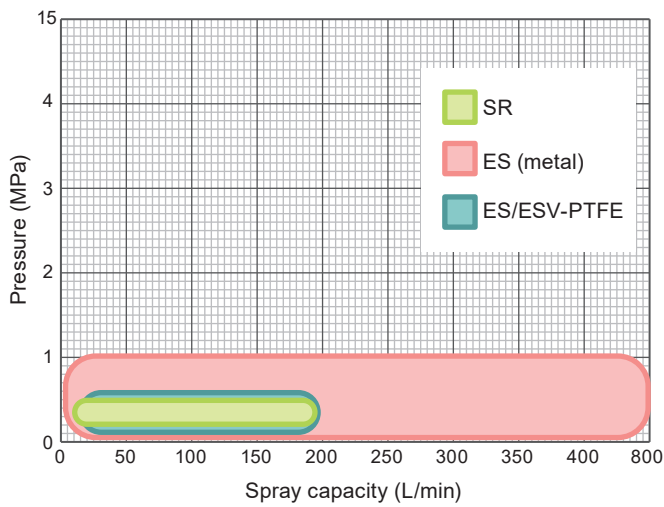

SWB Series

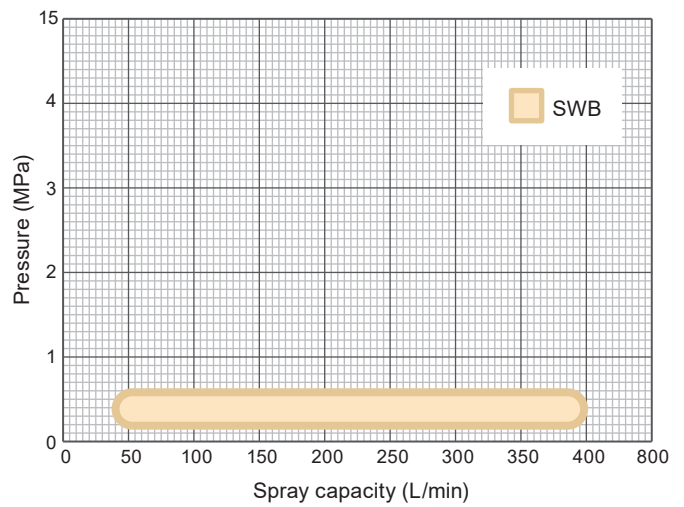

RJ Series

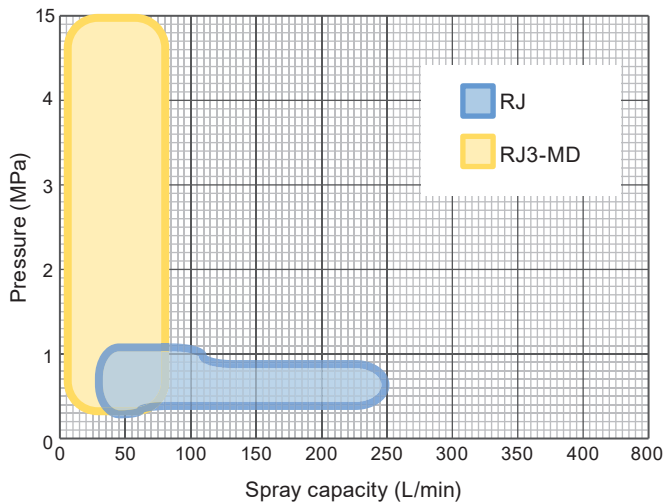

JA Series

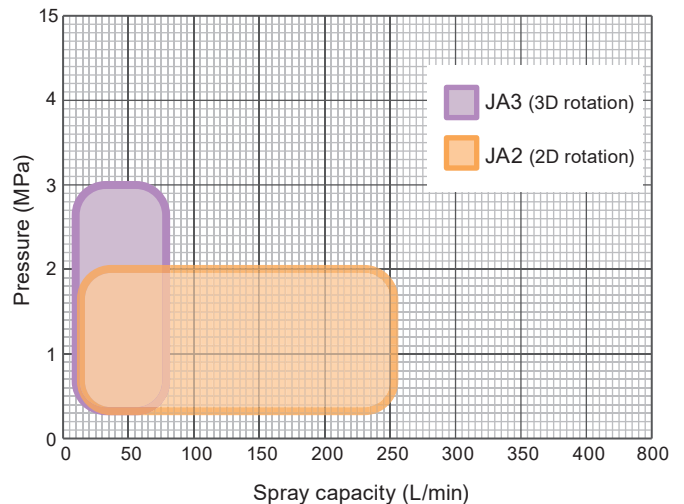

Nozzle Selection Guide by Application

Which nozzle is best for what application? Follow this flow chart and find out.

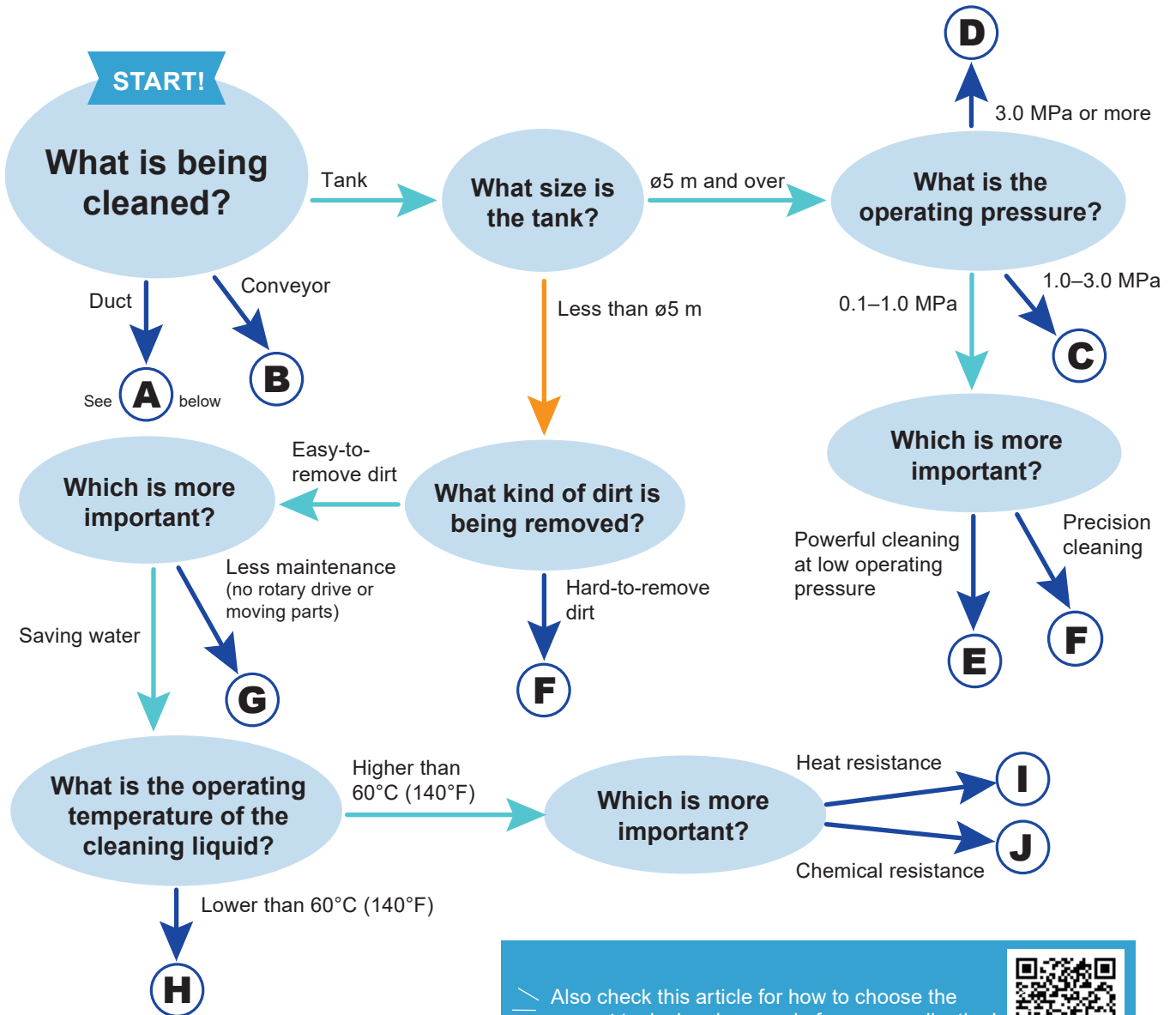

Also check this article for how to choose the correct tank cleaning nozzle for your application!

GOAL!

<p>A</p> <p>Ideal for duct cleaning!</p> <p>RJ2-PON SERIES (page 36)</p>	<p>B</p> <p>Powerful cleaning for conveyors!</p> <p>JA2 SERIES (2D rotation, page 31)</p>	<p>C</p> <p>Impact cleaning with a straight liquid stream!</p> <p>JA3-S SERIES (3D rotation, page 25)</p>	<p>D</p> <p>High impact cleaning! Can be used at pressures from 0.3 to 15 MPa.</p> <p>RJ3-MD SERIES (RJ with Motor, page 22)</p>	<p>E</p> <p>Powerful cleaning at low pressure!</p> <p>JA3-L SERIES (3D rotation, page 25)</p>
<p>F</p> <p>Precise and uniform cleaning with no gaps!</p> <p>RJ SERIES (page 19)</p>	<p>G</p> <p>Non-rotating nozzle, safe for use!</p> <p>SWB SERIES (page 34)</p>	<p>H</p> <p>Can be mounted in any direction (sideways, upward, downward)!</p> <p>ES (metal) SERIES (page 12)</p>	<p>I</p> <p>All stainless steel! Low-speed rotation for effective cleaning.</p> <p>SR SERIES (page 9)</p>	<p>J</p> <p>Made of PTFE, ideal for food products!</p> <p>ES/ESV-PTFE SERIES (page 16)</p>

Case Studies

Here are some examples from actual customers who solved their problems using IKEUCHI nozzles.

01

Pharmaceutical Industry

Cleaning Medical Devices

No more cleaning by hand. Fully automated cleaning to ensure hygiene.

Devices need to be cleaned after every use

It takes time and effort to clean medical tanks by hand and should be avoided due to sanitary consideration. Preventing accidents due to hands on work is something else to be considered. All these points made the client think about installing automated cleaning equipment.



Fully automated cleaning!
Use it with confidence

In order to work in a doctor's office the cleaning equipment needed to be compact and able to work with the water pressure coming from the tap. A small rotating cleaning nozzle was proposed and tested. After a successful trial, it was decided to incorporate the cleaning nozzle into the equipment.

The nozzle used in this case was **2D rotation/ flat spray nozzle ES Series** >>> For more details see **p.12**

02

Food and Brewing Industry

Brewing Process

By automating the draining of residue from the yeast tank all manual labor was eliminated.

Draining the cleaned tank took too long

At a beer factory, too much time was wasted draining residues from the yeast tank and cleaning the inside after use. Water had to be sprayed to dilute the highly viscous residue and draining it little by little took a lot of time. Cleaning multiple tanks took a whole day.



Solving a sticky situation.
Significant reduction in work time!

The proposal suggested a cleaning nozzle attached to the tank lid and using it like a shower. This agitated the residue while draining it and cleaned the tank at the same time. Automating the draining and cleaning of the tank eliminated the need for manual labor. In addition, cleaning multiple tanks simultaneously reduced the time needed to clean all tanks.

The nozzle used in this case was **non-rotation nozzle SWB Series** >>> For more details see **p.34**



Other examples can be requested from this website.

<https://www.kirinoikeuchi.co.jp/eng/download/?keyword=Case+Studies+Tank+Cleaning&type=voice>

03

Paper and Pulp Industry

Pulp Manufacturing Process

Automatic cleaning of raw material tanks cut the cleaning time in half and made simultaneous cleaning of multiple tanks possible.

Work more efficiently!
Eliminate waste!

A paper mill took 30 to 40 minutes to clean a single raw material tank by hand, keeping workers from doing anything else. They wanted to save time and labor.

A rotating cleaning nozzle with a proven track record was proposed and tested on-site for real-life results.



No more labor intensive work!

Automation cut the cleaning time by 20 to 25 minutes per tank and allowed for cleaning of multiple tanks simultaneously! This saved significant time and gave workers the opportunity to complete other tasks.

Satisfied with the results, the nozzles were purchased and are still being used.

The nozzle used in this case was **3D rotation/ solid stream spray RJ Series** >>> For more details see **p. 19**

04

Chemical Industry

Spray Drying

The cleaning liquid reaches 1.2 times further using a smaller and more cost effective nozzle.

Uneven cleaning...
Check the nozzle!

The site designed and manufactured spray dryers. This customer was using a pressure opening high-pressure rotating nozzle to clean the ducts, cyclones and powder tank after spray-drying. However, the wind blowing through the ducts was affecting the spray, blowing it around, which could result in uneven cleaning.



Compact and easy installation!

The customer wanted a product with higher performance and lower cost. To meet their requirement, we designed and offered a nozzle that can provide a stable spray with low speed rotation, not disturbed by wind. It turned out this nozzle made the cleaning liquid reach 1.2 times further. It also allowed for a reduction in the nozzle size with a lower cost.

The nozzle used in this case was **duct cleaning nozzle RJ2-PON Series** >>> For more details see **p. 36**

For cleaning easy to remove dirt

SR SERIES / Low-speed Rotation, Wide Area Cleaning

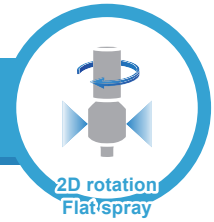

Cleaning easy to remove dirt



Unique, improved nozzle orifice configuration enables uniform cleaning and minimizes clogging.

Spray Coverage

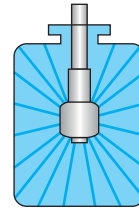

360° spray

Features

- Low-speed rotation of 3–15 rpm⁴ at 0.3 MPa maximizes contact time between cleaning surface and cleaning liquid for better cleaning effect.
- No external power is needed as rotation is driven solely by the flow of the cleaning liquid.

Applications

- Cleaning of various tanks, containers, filling machines, and conveyors

Basic Specifications

Operating Pressure Range
0.15–0.5 MPa (25–70 psi)

Material¹
S316L

Spray Capacity²
9.19–194 L/min

Weight³
55–1,410 g

Reach Distance of Spray (Diameter)
Approx. 2.0–5.8 m

Rotation Speed (at 0.3 MPa)⁴
3–15 rpm

Max. Temperature
150°C (302°F)

Outer Surface Finish
#320 buffing

¹In the material code, "S" represents "stainless steel".

²Spray flow rate in the above operating pressure range. See the flow-rate diagrams and chart for details.

³See the table in the drawing section.

⁴For reference only. Rotation speed varies depending on the pressure applied.

When using at low pressure, please allow sufficient cleaning time as the rotation speed decreases.

▼ Watch rotating & spraying nozzle on YouTube



IKEUCHI SR

Flow-rate Diagram

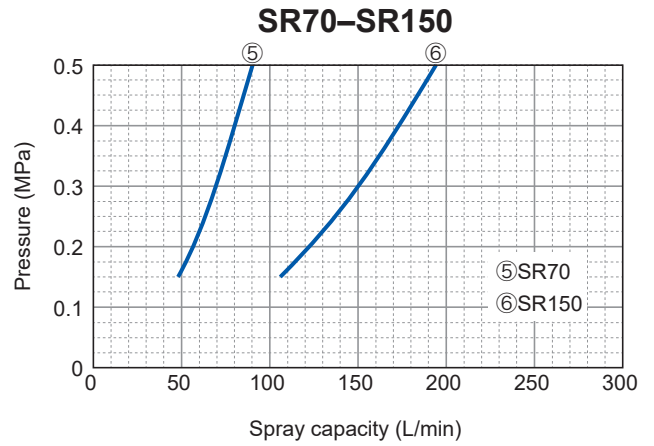
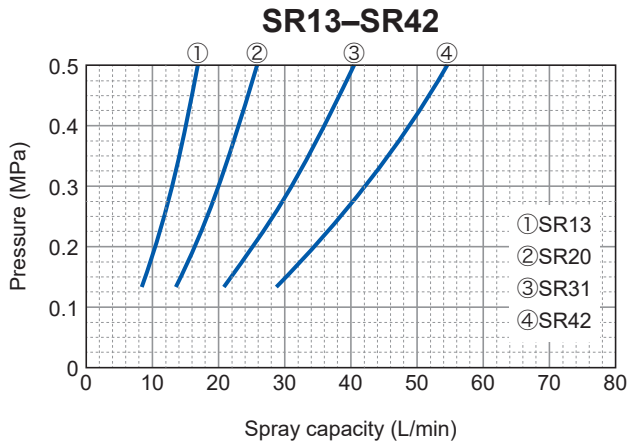

Flow-rate Chart

Spray capacity code	Pipe connection size	Spray capacity (L/min)		
		0.15 MPa	0.3 MPa	0.5 MPa
13	Rc1/8	9.19	13.0	16.8
20	Rc1/4	14.1	20.0	26.0
31	Rc3/8	21.9	31.0	40.0
42	Rc3/8	29.7	42.0	54.2
70	Rc1/2	49.5	70.0	90.4
150	Rc3/4	106	150	194

Reach Distance of Spray

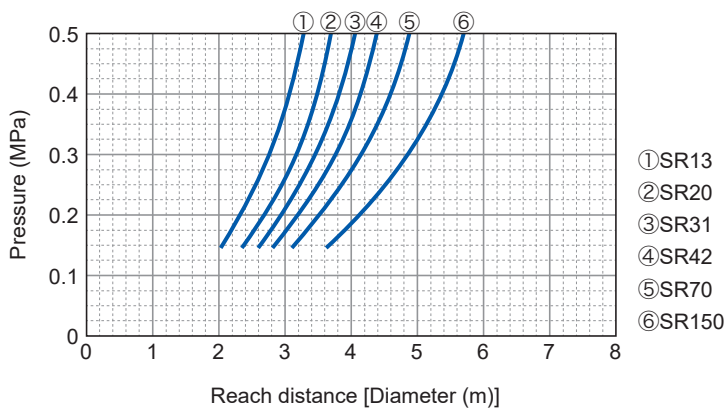

SR SERIES / Low-speed Rotation, Wide Area Cleaning

Cleaning easy to remove dirt

Drawing

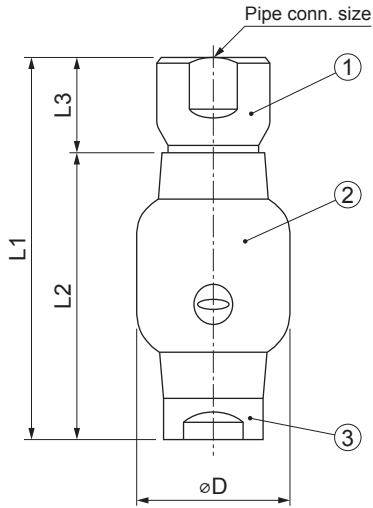

- ①Connecting adaptor
- ②Nozzle body (rotating part)
- ③Shaft bearing



■Dimensions and weight

Pipe conn. size	Outer dimensions (mm)				Weight (g)
	L1	L2	L3	øD	
Rc1/8	50	37	13	20	55
Rc1/4	62.5	47	15.5	25	110
Rc3/8	75	56	19	30	170
Rc1/2	100	75	25	40	410
Rc3/4	150	113	37	60	1,410

HOW TO ORDER

To inquire about or order a specific product please refer to this coding system.

Example: 1/8F SR 13 N S316L (360)

1/8F SR 13 N S316L (360)

Pipe Conn. Size ⁵		Spray Capacity Code	
■1/8F	■1/4F	■13	■20
■3/8F	■1/2F	■31	■42
■3/4F		■70	■150

⁵ "F" indicates female tapered pipe thread ("Rc" of the ISO standard), e.g. 1/4F = Rc1/4.

For cleaning easy to remove dirt

ES SERIES / Metal / Self-cleaning, Easy Maintenance



Cleaning easy to remove dirt



Innovative slit design eliminates blind spots and self-cleaning function.

Spray Coverage

Select from three patterns.

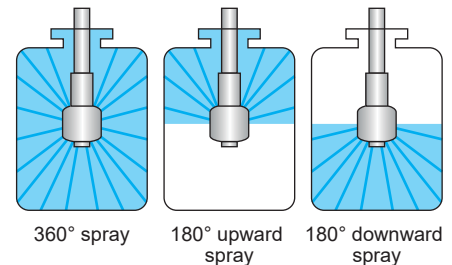

Note: ES with 180° upward spray has two holes in the bottom of the nozzle body (rotating part) for drainage.

Features

- No external power is needed as rotation is driven solely by the flow of the cleaning liquid.
- Maintenance is easy due to the low parts count.
- Internal design greatly reduces dripping from the nozzle tip. Maintains high level of cleanliness because it is self-cleaning.
- ES series can be installed in any direction, vertically, horizontally or diagonally.
- Available in two types of connections: thread connection (ES-N) and pin connection (ES-P).

Applications

- Cleaning of a variety of tanks, such as mixing, blending, and storage tanks
- CIP cleaning
- Cleaning the inside of conveyor tunnels and ovens

Basic Specifications

■ Operating Pressure Range 0.1–1.0 MPa (15–145 psi)	■ Material ¹ Metal parts: S316L Shaft bearings: PTFE
■ Spray Capacity ² 4.0–803.3 L/min	■ Weight ³ 20–1,820 g
■ Reach Distance of Spray (Diameter) Approx. 0.5–7.3 m	■ Rotation Speed (at 0.3 MPa) ⁴ 60–120 rpm
■ Max. Temperature 60°C (140°F)	■ Outer Surface Finish #320 buffing

¹In the material code, "S" represents "stainless steel".

²Spray flow rate in the above operating pressure range. See the flow-rate diagrams and chart for details.

³See the table in the drawing section.

⁴For reference only. Rotation speed varies depending on the pressure applied.

ES SERIES / Metal / Self-cleaning, Easy Maintenance

Cleaning easy to remove dirt

Flow-rate Diagram

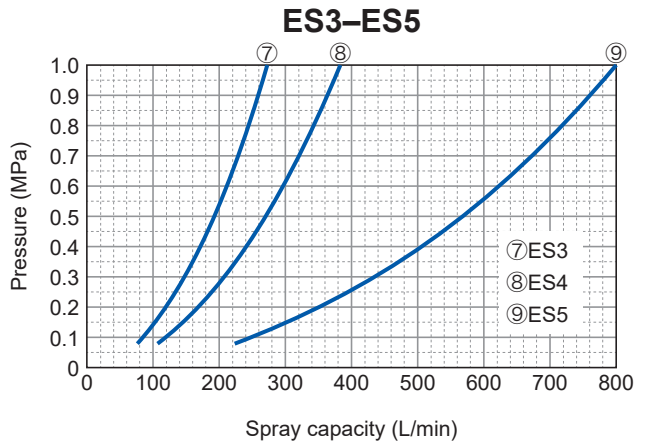
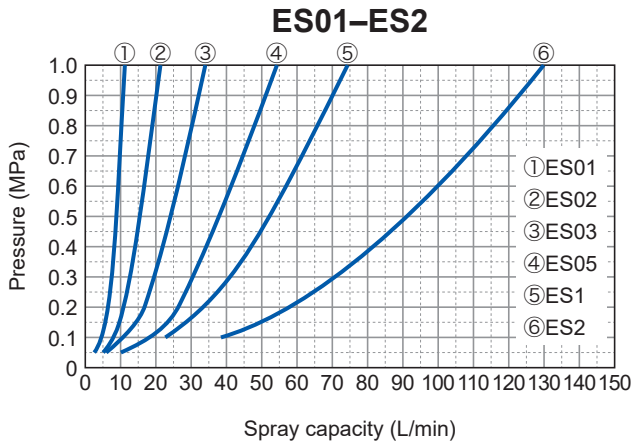

Flow-rate Chart

Spray capacity code	Pipe connection size ^{*5}		Spray capacity (L/min)				
	[ES-N] Thread connection	[ES-P] Pin connection	0.1 MPa	0.3 MPa	0.5 MPa	0.7 MPa	1.0 MPa
01	Rc1/8	∅10	4.0	7	9.0	10.7	12.8
02	Rc1/8	∅13	7.5	13	16.8	19.9	23.7
03	Rc1/4	∅17	11.5	20	25.8	30.6	36.5
05	Rc3/8	∅21	17.9	31	40.0	47.4	56.6
1	Rc3/8	∅21	24.2	42	54.2	64.2	76.7
2	Rc1/2	∅25	40.4	70	90.4	106.9	127.8
3	Rc3/4	∅38	86.6	150	193.6	229.1	273.9
4	Rc1	∅38	121.2	210	271.1	320.8	383.4
5	Rc1½	∅50	254.0	440	568.0	672.1	803.3

^{*5}As for the ES-P, it only indicates the connection code, not an exact pin size or pipe diameter. For details see the drawing and dimension table on page 14.

Reach Distance of Spray

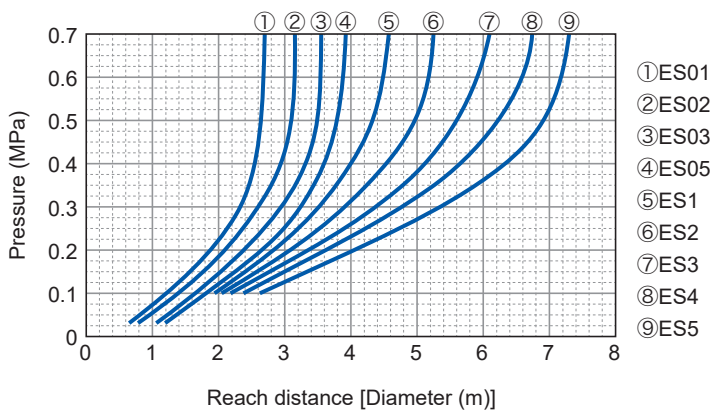

Drawing

ES-N
(Thread connection)

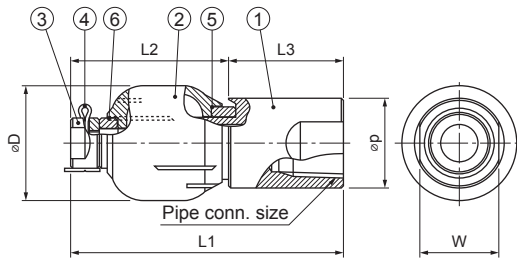

ES-P
(Pin connection)

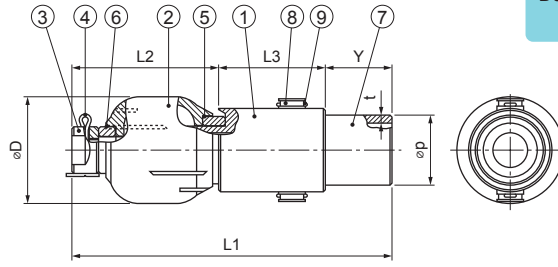

Download 3D/2D
CAD file

- ①Connecting adaptor ②Nozzle body (rotating part) ③Hub ④Lock pin ⑤Upper shaft bearing (PTFE)
⑥Lower shaft bearing (PTFE) ⑦Welded connecting pipe ⑧Connecting pin ⑨Side pin

■Dimensions and weight

Spray capacity code	Pipe connection code and size		Outer dimensions (mm)							Weight (g)	
			L1	L2	L3	W	øD	Y	øp		t
01	N (thread)	Rc1/8	38	22	16	11	16	—	12.5	—	20
	P (pin)	6A (ø10.5)	48			—		10	10.5	1.2	25
02	N (thread)	Rc1/8	53	28.5	24.5	12	20	—	13	—	35
	P (pin)	8A (ø13.8)	73			—		20	13.8	1.2	50
03	N (thread)	Rc1/4	65	35	30	16.5	25	—	18	—	75
	P (pin)	10A (ø17.3)	90			—		25	17.3	1.5	90
05	N (thread)	Rc3/8	97	52	45	20	30	—	22	—	155
	P (pin)	15A (ø21.7)	127			—		30	21.7	1.5	210
1	N (thread)	Rc3/8	115	60	55	20	31.5	—	22	—	185
	P (pin)	15A (ø21.7)	145			—		30	21.7	1.5	235
2	N (thread)	Rc1/2	123	68	55	23	41.5	—	25	—	260
	P (pin)	1S (ø25.4)	153			—		30	25.4	1.5	315
3	N (thread)	Rc3/4	139	79	60	23	60	—	35	—	605
	P (pin)	1.5S (ø38.1)	174			—		35	38.1	1.5	660
4	N (thread)	Rc1	163	93	70	37.6	75	—	40	—	925
	P (pin)	1.5S (ø38.1)	198			—		35	38.1	1.5	1,060
5	N (thread)	Rc1½	180	105	75	52	88	—	55	—	1,640
	P (pin)	2S (ø50.8)	225			—		45	50.8	1.5	1,820

ES SERIES / Metal / Self-cleaning, Easy Maintenance

Cleaning easy
to remove dirt

Internal Design

The ES-P, pin connection model, is very clean since there are no threads in the flow passage where contaminants could collect.

In both models, the ES-N and ES-P, the cleaning liquid flows from openings between the connecting adaptor and nozzle body (rotating part), keeping the nozzle surface clean.

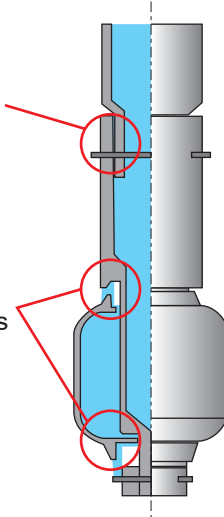

HOW TO ORDER

To inquire about or order a specific product please refer to this coding system.

Example: 1/8F ES 01 N S316L (360)

1/8F	ES	01	N	S316L	(360)
Pipe Conn. Size ^{*5, *6}		Spray Capacity Code	Connection Code		Spray Coverage Pattern
[ES-N] ■ 1/8F ■ 1/4F ■ 3/8F ■ 1/2F ■ 3/4F ■ 1F ■ 1*1/2F	[ES-P] ■ ø10 ■ ø13 ■ ø17 ■ ø21 ■ ø25 ■ ø38 ■ ø50	■ 01 ■ 02 ■ 03 ■ 05 ■ 1 ■ 2 ■ 3 ■ 4 ■ 5	■ N (thread connection) ■ P (pin connection)		■ 360 ■ 180 upward ■ 180 downward

^{*6} "F" indicates female tapered pipe thread ("Rc" of the ISO standard), e.g. 1/4F = Rc1/4.

For cleaning easy to remove dirt

ES/ESV-PTFE SERIES / Resistant to Chemicals

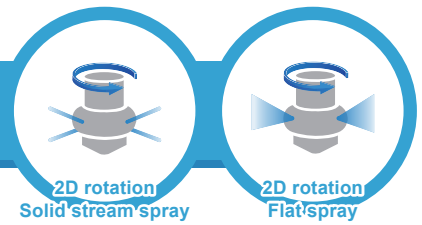

Spray Coverage

Select from three patterns for the ES.
The ESV is only available for the 360° spray.

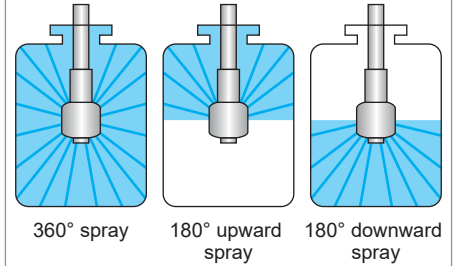

Cleaning easy to remove dirt

Features

- Made of PTFE, highly resistant to chemicals.
- Rotating flat spray pattern covers the entire surface in a tank (ESV series).
- No external power is needed as rotation is driven solely by the flow of the cleaning liquid.

Applications

- Cleaning of chemical tanks, containers, filling machines, can be used with acid or alkali cleaner.

Basic Specifications

Operating Pressure Range
0.05–0.5 MPa (8–70 psi)

Material
PTFE

Spray Capacity^{*1}
12.2–194 L/min

Weight
Pipe conn. size Rc1/2: 130 g
Pipe conn. size Rc3/4: 180 g

Reach Distance of Spray (Diameter)
ES: approx. 1.5–4 m
ESV: approx. 1.1–4 m

Rotation Speed
N/A

Max. Temperature
93°C (199°F)

^{*1} Spray flow rate in the above operating pressure range is for reference only.
See the flow-rate diagram and chart for more details.

▼ Watch rotating & spraying nozzle on YouTube



IKEUCHI ES-PTFE

ES-PTFE, ESV-PTFE SERIES / Resistant to Chemicals

Cleaning easy to remove dirt

Flow-rate Diagram

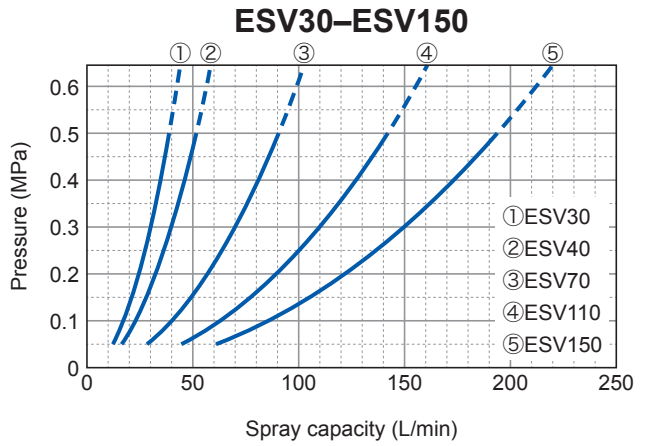
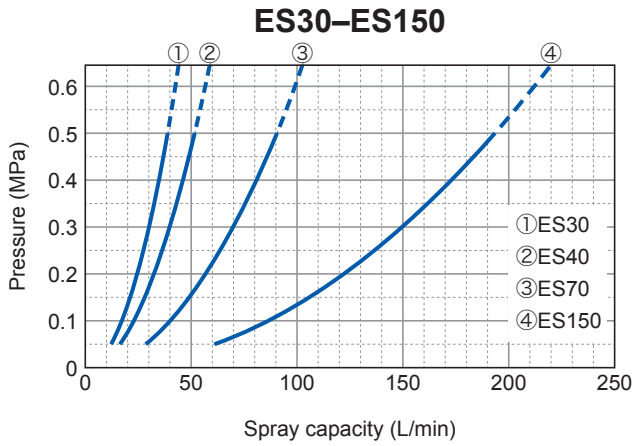

Flow-rate Chart

Series		Spray capacity code	Pipe conn. size	Spray capacity (L/min) [for reference only]					
ES	ESV			0.05 MPa	0.1 MPa	0.2 MPa	0.3 MPa	0.4 MPa	0.5 MPa
○	○	30	Rc1/2	12.2	17.3	24.5	30.0	34.6	38.7
○	○	40	Rc1/2	16.3	23.1	32.7	40.0	46.2	51.6
○	○	70	Rc3/4	28.6	40.4	57.2	70.0	80.8	90.4
—	○	110	Rc3/4	44.9	63.5	89.8	110	127	142
○	○	150	Rc3/4	61.2	86.6	123	150	173	194

○ shows availability of the item.

Reach Distance of Spray

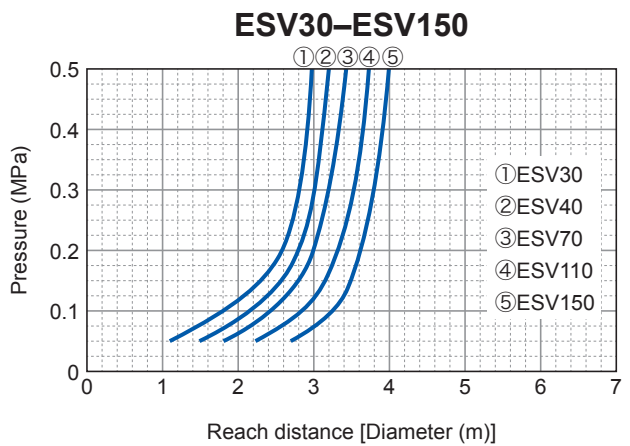
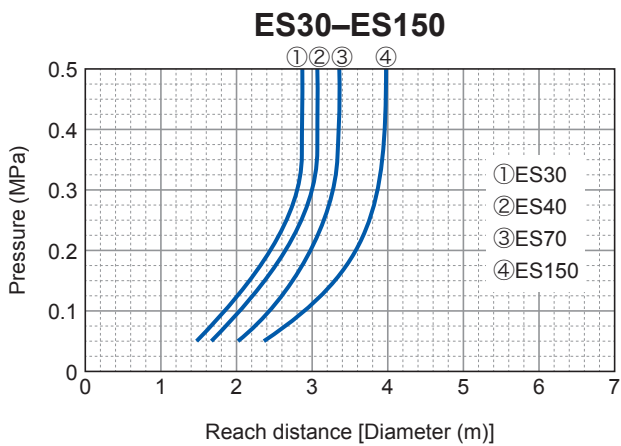

ES-PTFE, ESV-PTFE SERIES / Resistant to Chemicals

Cleaning easy
to remove dirt

Drawing

ES-PTFE

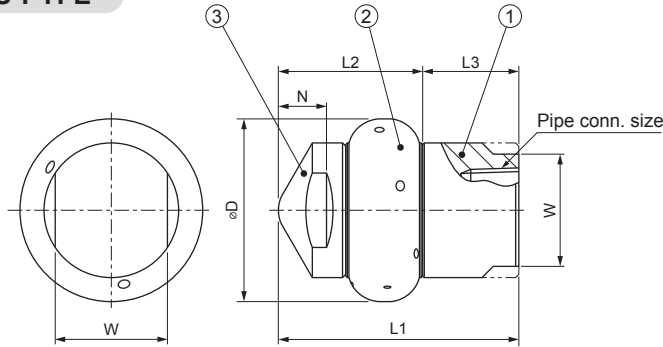

- ① Connecting adaptor
- ② Nozzle body (rotating part)
- ③ Hub



Download 3D/2D
CAD file

ESV-PTFE

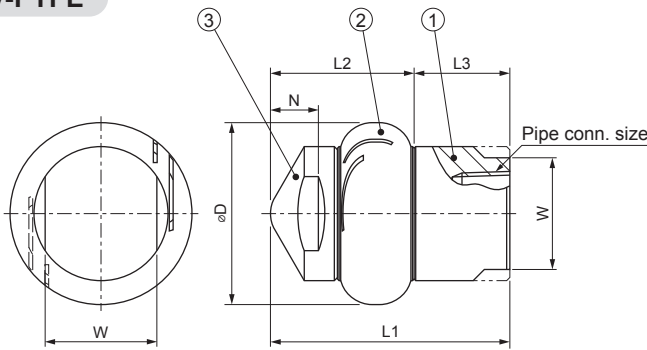

- ① Connecting adaptor
- ② Nozzle body (rotating part)
- ③ Hub

■ Dimensions and weight

Series	Pipe conn. size	Outer dimensions (mm)						Weight (g)
		L1	L2	L3	W	$\varnothing D$	N	
ES	Rc1/2	65	41	24	30	50	14	130
	Rc3/4	75	45	30	35	57	15	180
ESV	Rc1/2	65	41	24	30	50	12	130
	Rc3/4	75	45	30	35	57	15	180

HOW TO ORDER

To inquire about or order a specific product please refer to this coding system.

ES-PTFE

Example: 1/2F ES 30 N PTFE (360)

1/2F ES 30 N PTFE (360)

Pipe Conn. Size²

- 1/2F
- 3/4F

Spray Capacity Code

- 30
- 40
- 70
- 150

Spray Coverage Pattern

- 360
- 180 upward
- 180 downward

ESV-PTFE

Example: 1/2F ESV 30 N PTFE (360)

1/2F ESV 30 N PTFE (360)

Pipe Conn. Size²

- 1/2F
- 3/4F

Spray Capacity Code

- 30
- 40
- 70
- 110
- 150

² "F" indicates female tapered pipe thread ("Rc" of the ISO standard), e.g. 1/2F = Rc1/2.



Cleaning hard to remove dirt

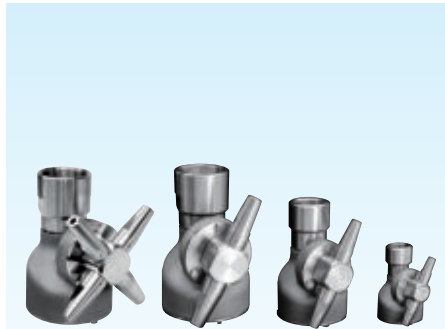

Spray Coverage

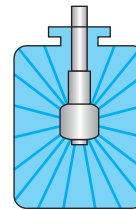

360° spray

Note: RJ has two holes in the bottom of the body for drainage.

Features

- Powerful 3D rotational solid stream jet cleans the inside of tanks.
- No external power is needed as rotation is driven solely by the flow of the cleaning liquid.
- Heat-resistant up to 80 deg. C (176 deg. F).³
- Compact design allows for easy installation even if the inlet is small.
- Insertion and removal is easy since the rotating nozzle is not locked into place.
- The RJ3-2L is equipped with two nozzles, and the RJ3-4L with four nozzles.
- A customized option: The submerged type can be left in place during the normal operational use of the tank without affecting its performance during cleaning. For more details, please contact us.

Applications

- Removing tough, sticky and stubborn dirt
- Cleaning of food and beverage tanks
- Cleaning inside the chests (material tanks of paper making), etc.

Basic Specifications

Operating Pressure Range
 1/2F RJ3-2L: 0.2–1.0 MPa (30–145 psi)
 1F RJ3-2L: 0.3–1.0 MPa (45–145 psi)
 1*1/2F RJ3-2L/4L: 0.3–0.8 MPa (45–115 psi)

Spray Capacity²
 25.6–246 L/min

Reach Distance of Spray (RADIUS)
 1/2F RJ3-2L: about 7 m
 1F RJ3-2L: about 9 m
 1*1/2F RJ3-2L-ø7 or ø8: about 10 m
 1*1/2F RJ3-2L-ø9: about 12 m
 1*1/2F RJ3-4L: about 9 m

Max. Temperature³
 80°C (176°F)

Main Material¹
 1/2F&1F RJ: S304, SCS14, UPE, PTFE, PEEK
 1*1/2F RJ: S304, SCS13, UPE, PTFE, PEEK

Weight
 1/2F RJ3-2L: 0.62 kg
 1F RJ3-2L: 1.9 kg
 1*1/2F RJ3-2L: 2.7 kg
 1*1/2F RJ3-4L: 2.8 kg

Rotation Speed
 N/A

Outer Surface Finish
 #320 buffing is optional and available upon request for an additional charge.

▼ Watch rotating & spraying nozzle on YouTube



IKEUCHI RJ

¹ In the material code, "S" represents "stainless steel". SCS13 is cast stainless steel equivalent to S304. SCS14 is cast stainless steel equivalent to S316.
² Spray flow rate in the above operating pressure range is for reference only. See the flow-rate diagram and chart for more details.
³ A heat-resistant type, suitable for use over 80°C, is also available as a custom-made option. Please contact us for more details.

Flow-rate Diagram

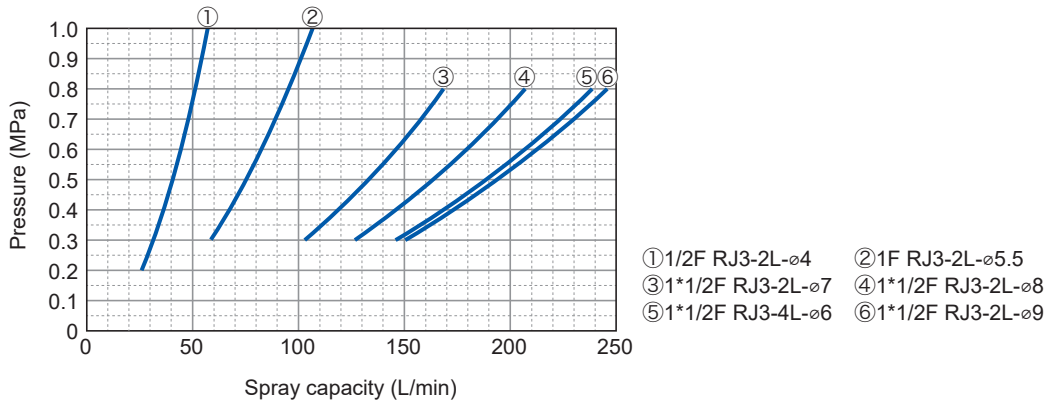

Flow-rate Chart

Model No. (RJ3-)	Nozzle orifice diameter (mm)	Pipe conn. size	Spray capacity (L/min) [for reference only]								
			0.2 MPa	0.3 MPa	0.4 MPa	0.5 MPa	0.6 MPa	0.7 MPa	0.8 MPa	0.9 MPa	1.0 MPa
2L- ϕ 4	4	Rc1/2	25.6	31.4	36.2	40.5	44.4	47.9	51.2	54.3	57.3
2L- ϕ 5.5	5.5	Rc1	—	58.3	67.3	75.3	82.4	89.1	95.2	101	106.4
2L- ϕ 7	7	Rc1½	—	103	119	133	146	158	169	—	—
2L- ϕ 8	8	Rc1½	—	127	146	164	179	194	207	—	—
4L- ϕ 6	6	Rc1½	—	146	169	189	207	223	239	—	—
2L- ϕ 9	9	Rc1½	—	151	174	194	213	230	246	—	—

Pressure and Cleaning Cycle

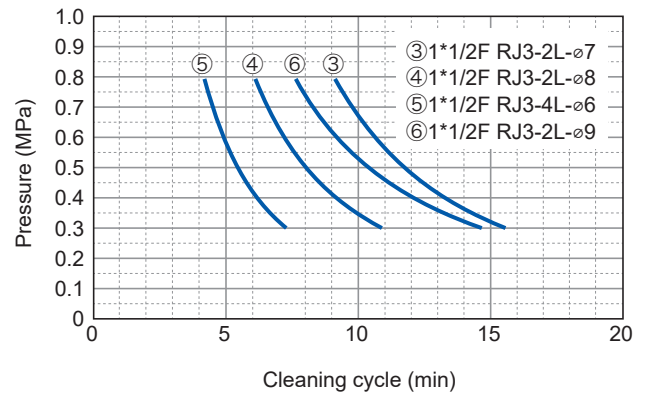
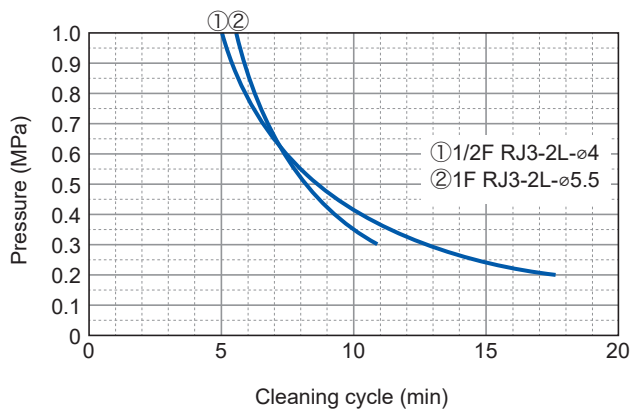

RJ SERIES / ROTARY JETTER / Powerful 3D Rotational Cleaning

Cleaning hard to remove dirt

Drawing

1/2F RJ3-2L (with 2 nozzles)

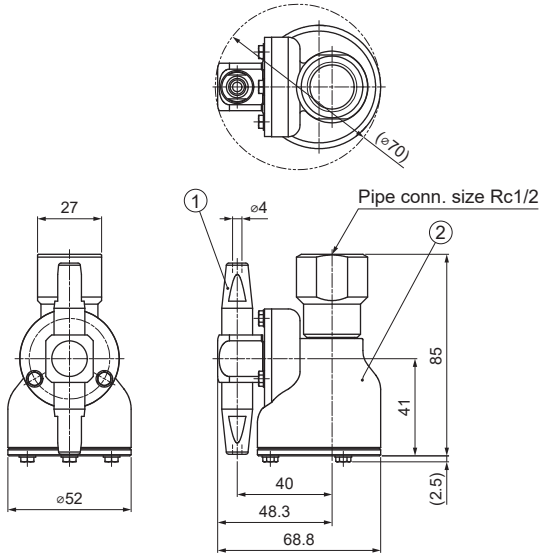

1F RJ3-2L (with 2 nozzles)

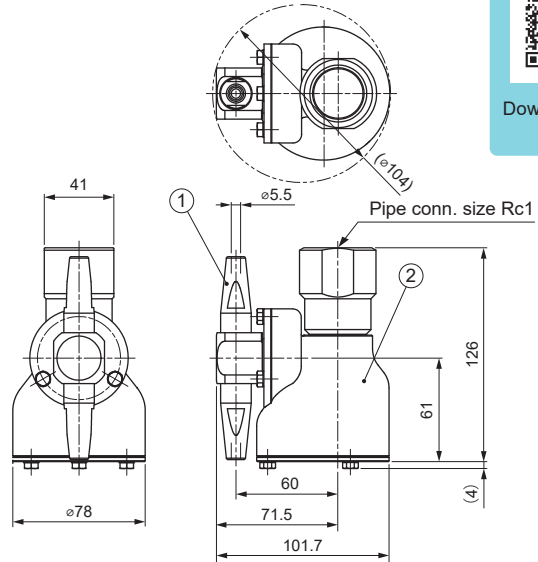

Download 3D/2D CAD file

1*1/2F RJ3-2L (with 2 nozzles)

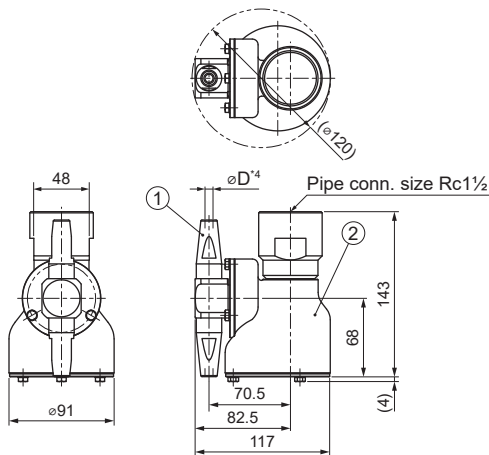

1*1/2F RJ3-4L (with 4 nozzles)

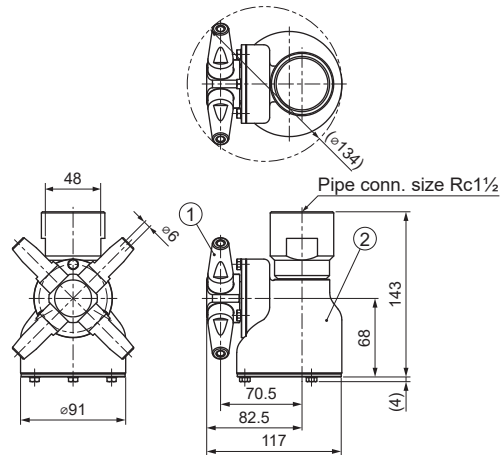

⁴Nozzle orifice diameter is shown in $\varnothing D$ (either $\varnothing 7$, $\varnothing 8$, or $\varnothing 9$).

① Nozzle ② Body

Unit: mm

HOW TO ORDER

To inquire about or order a specific product please refer to this coding system.

Example: 1*1/2F RJ 3-2L- $\varnothing 7$

1*1/2F RJ 3 - 2L - $\varnothing 7$

Pipe Conn. Size⁵

- 1/2F
- 1F
- 1*1/2F

Number of Nozzles Attached

- 2L (with 2 nozzles)
- 4L (with 4 nozzles)

Nozzle Orifice Diameter

- $\varnothing 4$
- $\varnothing 5.5$
- $\varnothing 6$
- $\varnothing 7$
- $\varnothing 8$
- $\varnothing 9$

⁵"F" indicates female tapered pipe thread ("Rc" of the ISO standard), e.g. 1/2F = Rc1/2.

For cleaning hard to remove dirt

RJ3-MD SERIES with Air/Electric Motor for Powerful Cleaning

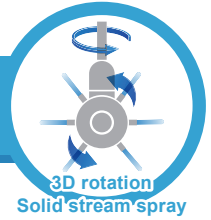

Made-to-Order



Spray Coverage

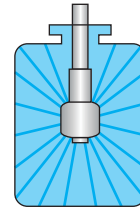

360° spray

Cleaning hard to remove dirt

Features

- 3D rotation solid stream jet powerfully cleans the inside of a tank.
- Stable low-speed rotation with motor maximizes contact time between cleaning surface and cleaning liquid for effective cleaning.
- Models come with two, three, or six nozzles for precision cleaning.
- Heat-resistant up to 80 deg. C (176 deg. F).

Applications

- Removing tough, sticky and stubborn dirt
- Cleaning of reactor vessels in chemical plants

Air Motor

Compressed air drives the motor.
Stainless steel air motor requires no oil to operate.

Electric Motor

Immediate use and stable rotation anywhere a power supply is available. No adjustment required.

Note: There is no ON/OFF switch on the product. Please control the operation by turning ON/OFF the supply of compressed air or electricity.

Basic Specifications

Operating Pressure Range 0.3–15 MPa (45–2,170 psi)	Main Material¹ S304, SCS14, ABB2 + bronze alloy, UPE (seal), FKM (O-ring)
Number of Nozzles Attached 2, 3, or 6	Approx. Weight (w/o flange) RJ3-AMD (air motor): 11–16 kg RJ3-EMD (electric motor): 14–19 kg
Spray Capacity² 2 nozzles: 4.2–80.3 L/min 3 nozzles: 6.3–98.0 L/min 6 nozzles: 6.4–103.7 L/min	Compressed Air Pressure (only for RJ3-AMD) 0.3–0.5 MPa (45–70 psi)
Max. Temperature 80°C (176°F)	Air Consumption (only for RJ3-AMD) 100–170 L/min, Normal
Reach Distance of Spray (RADIUS)³ Approx. 1.5–2.5 m	Power Voltage (of RJ3-EMD) 100 VAC
Rotation Speed RJ3-AMD (air motor): 5–10 rpm RJ3-EMD (electric motor): 6 rpm (50 Hz), 7.2 rpm (60 Hz)	Power Consumption (of RJ3-EMD) 40 W
Cleaning Cycle RJ3-AMD (air motor): 7.4–3.7 min RJ3-EMD (electric motor): 6.2 min (50 Hz), 5.2 min (60 Hz)	

▼ Watch rotating & spraying nozzle on YouTube



IKEUCHI RJ3-MD

¹In the material code, "S" represents "stainless steel". SCS14 is cast stainless steel equivalent to S316.

²Spray flow rate in the above operating pressure range is for reference only. See the flow-rate diagram and chart for more details.

³Spray reach distance varies depending on the number of nozzles attached and the nozzle orifice diameter. Contact us for details.

RJ3-MD SERIES with Air/Electric Motor for Powerful Cleaning

Flow-rate Diagram ① to ⑫ indicate the nozzle orifice diameters.

■ RJ3-AMD/EMD-2 (with 2 nozzles)

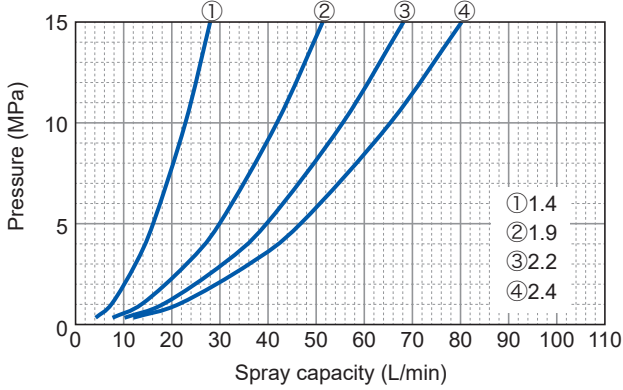

■ RJ3-AMD/EMD-3 (with 3 nozzles)

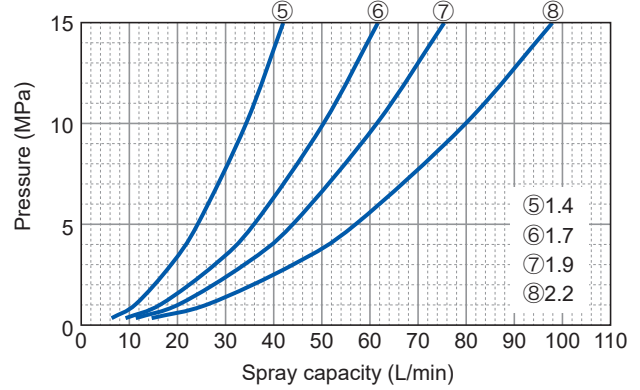

■ RJ3-AMD/EMD-6 (with 6 nozzles)

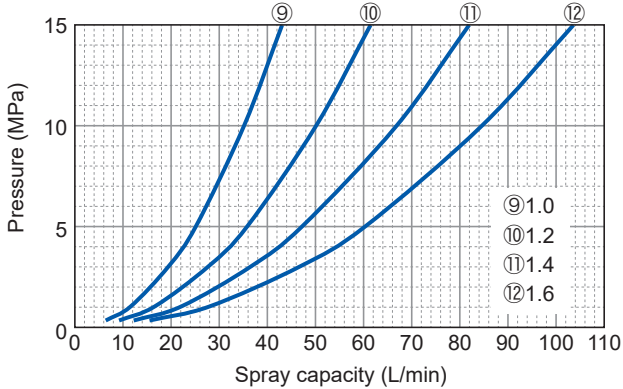

Flow-rate Chart

Number of nozzles attached	Nozzle orifice diameter (mm)	Spray capacity (L/min) [for reference only]					
		0.3 MPa	1 MPa	3 MPa	5 MPa	10 MPa	15 MPa
2	1.4	4.2	7.6	12.5	16.2	22.9	28.0
	1.9	7.7	13.9	23.2	30.0	41.9	51.4
	2.2	10.2	18.4	30.8	39.8	55.6	68.2
	2.4	12.0	21.7	36.3	46.9	65.5	80.3
3	1.4	6.3	11.3	18.8	24.2	34.3	42.0
	1.7	9.2	16.6	27.9	36.0	50.4	61.7
	1.9	11.3	20.4	34.1	44.1	61.5	75.5
	2.2	14.6	26.4	44.3	57.2	80.0	98.0
6	1.0	6.4	11.6	19.5	25.2	35.2	43.1
	1.2	9.2	16.6	27.8	35.9	50.2	61.5
	1.4	12.2	22.1	36.7	47.3	67.0	82.0
	1.6	15.5	28.0	46.9	60.5	84.7	103.7

RJ3-MD SERIES with Air/Electric Motor for Powerful Cleaning

Drawing

Unit: mm

RJ3-AMD

(with Air Motor)

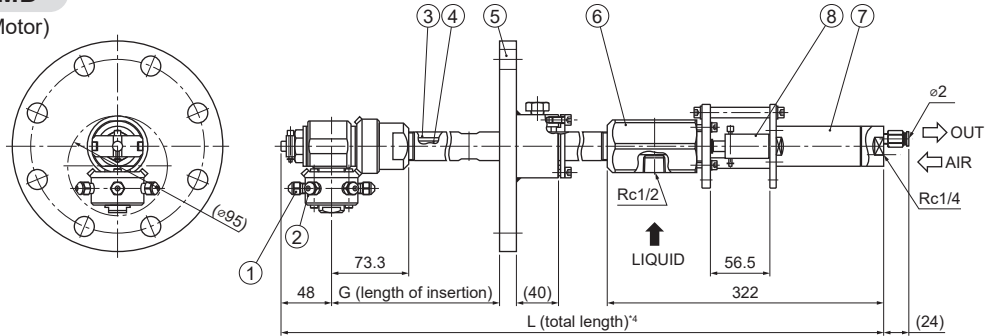

- ① Nozzle ② Nozzle header ③ Pipe (3/4B x Sch160 equiv.) ④ Rotating shaft ⑤ Flange
⑥ Adaptor for high-pressure water supply ⑦ Air motor ⑧ Motor coupling adaptor

RJ3-EMD

(with Electric Motor)

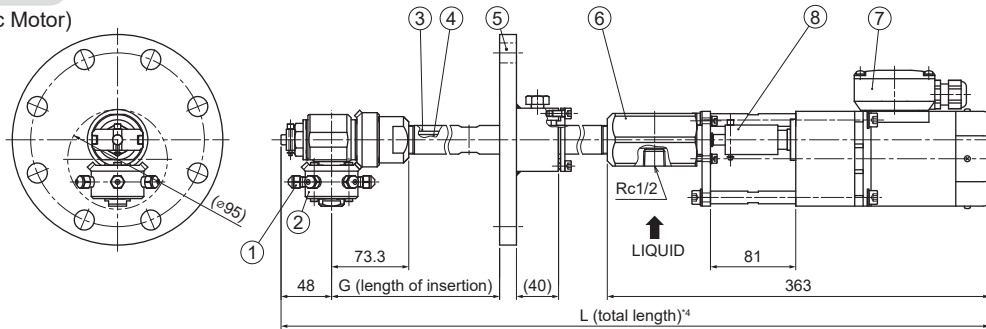

- ① Nozzle ② Nozzle header ③ Pipe (3/4B x Sch160 equiv.) ④ Rotating shaft ⑤ Flange
⑥ Adaptor for high-pressure water supply ⑦ Electric motor ⑧ Motor coupling adaptor

■ Dimensions and weight

Length type	Outer dimensions (mm)		Diameter required for insertion (mm)	Approx. weight (kg) w/o flange
	L (total length) ⁴	G (length of insertion)		
A	AMD	870	150-380	11
	EMD	911		14
B	AMD	1370	150-880	13
	EMD	1411		16
C	AMD	1870	150-1380	15
	EMD	1911		18
D	AMD	2170	150-1680	16
	EMD	2211		19

Note:
A diameter of more than 95 mm is needed to insert the nozzle unit.

⁴The total length L differs for each motor. Select from the above A to D.

HOW TO ORDER

To inquire about or order a specific product please refer to this coding system.

Example: RJ3-AMD 6 - ϕ 1.4 - 4T5 \times B - BF E*** S304

RJ3 - AMD 6 - ϕ 1.4 - 4T5 \times B - BF E*** S304

Motor Type ⁵	Number of Nozzles	Nozzle Orifice Diameter	Total Length ⁴	Buffing ⁶	Spec. Registration No. ⁷
■ AMD	■ 2	■ 1.0-2.4	■ A ■ B	■ BF (optional)	
■ EMD	■ 3	(See the chart on page 23)	■ C ■ D		
	■ 6				

⁵ Indicate "AMD" for air motor, or "EMD" for electric motor.

⁶ Buffing is optional, available for extra charge. Leave blank if buffing is not necessary.

⁷ IKEUCHI will assign a number after specification is determined.

Cleaning hard to remove dirt

For cleaning hard to remove dirt

JET ATTACKER

JA3 SERIES / Powerful 3D Rotational Cleaning

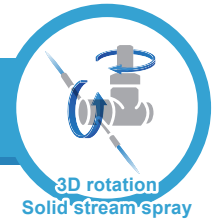

Cleaning hard to remove dirt

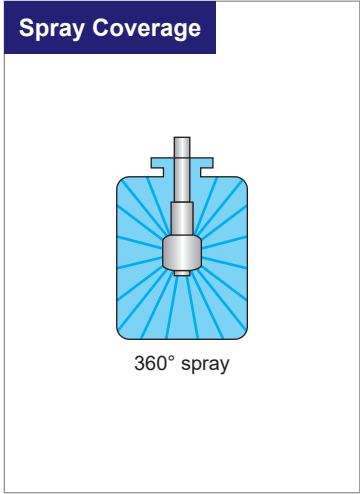

Features

- Three-dimensional rotating solid stream jets powerfully clean the inside of a tank.
- No external power is needed as rotation is driven solely by the flow of the cleaning liquid.
- Simple structure, no turbine or reduction gears.
- Compact and lightweight, at less than 2 kg, with a maximum arm diameter of 240 mm, ensuring reliable cleaning.
- Available for low- and medium-pressure use. The JA3-2L series uses 0.3–1.2 MPa to clean with spray flow volume and the JA3-2S/4S series uses 1.0–3.0 MPa to clean with spray pressure.
- The JA3-2L/2S series is equipped with two nozzles, and the JA3-4S series with four nozzles.
- Easy to install, reducing equipment costs.

Applications

- Removing tough, sticky and stubborn dirt
- Cleaning of tanks for brewing, fermentation, distillation and storage, cleaning of transport containers

Basic Specifications

<p>■ Operating Pressure Range JA3-2L (low-pressure use): 0.3–1.2 MPa (45–170 psi) JA3-2S/4S (medium-pressure use): 1.0–3.0 MPa (150–430 psi)</p>	<p>■ Number of Nozzles Attached JA3-2L/2S with two nozzles JA3-4S with four nozzles</p>
<p>■ Spray Capacity² JA3-2L: 24–82 L/min JA3-2S: 12–36 L/min JA3-4S: 24–70 L/min</p>	<p>■ Main Material¹ S304, SCS14, S303, PTFE, FKM, S440C</p>
<p>■ Reach Distance of Spray (Diameter) JA3-2L: approx. 2–7 m JA3-2S/4S: approx. 6–9 m</p>	<p>■ Weight³ 1.70–1.95 kg</p>
<p>■ Max. Temperature 60°C (140°F)</p>	<p>■ Rotation Speed⁴ 30–60 rpm</p>
	<p>■ Outer Surface Finish #320 buffing</p>

▼ Watch rotating & spraying nozzle on YouTube

JA3-2L



JA3-4S



IKEUCHI JA

¹In the material code, "S" represents "stainless steel". SCS14 is cast stainless steel equivalent to S316.

²Spray flow rate in the above operating pressure range is for reference only. See the flow-rate diagram and chart for more details.

³See the table in the drawing section.

⁴Set to this range of rotation speed at a pressure specified prior to shipping. The rotation speed varies depending on the applied pressure.

JA3 SERIES / JET ATTACKER / Powerful 3D Rotational Cleaning

- The liquid pressure and spray flow rate should be set based on your specific applications and requirements.
- Two- and four-nozzle models are available, each with two options for the nozzle orifice diameter.
- The JA3-2S/4S models with their medium-pressure specifications are recommended for use at pressures of 1.0–3.0 MPa. When used at higher pressure, the rotation speed will become too high and the spray will become erratic.

Flow-rate Diagram

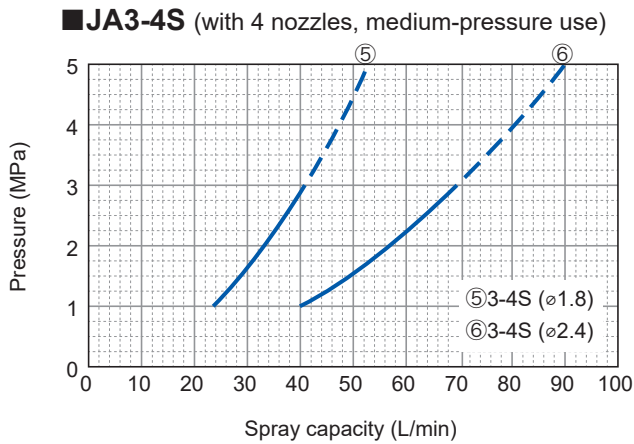
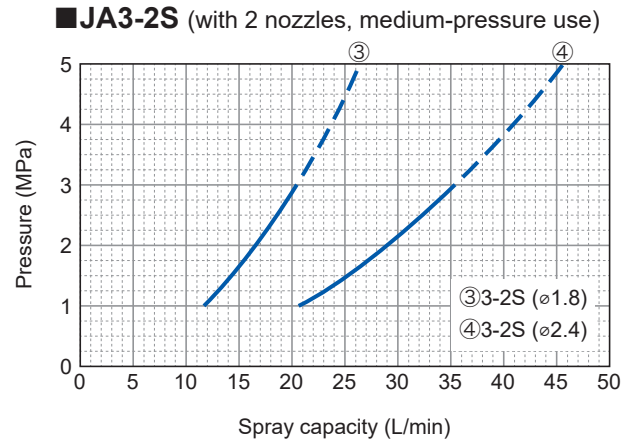
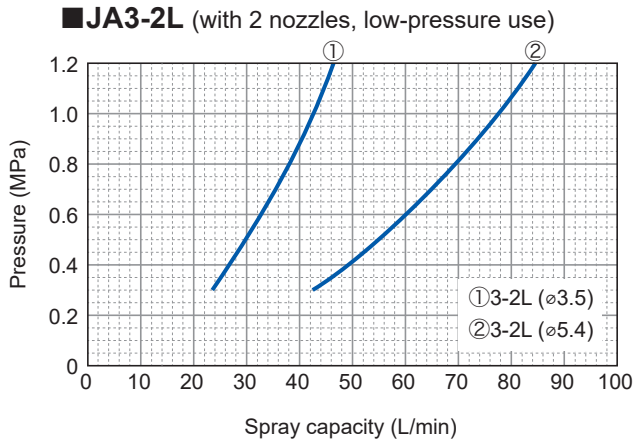

Flow-rate Chart

Model No. (JA...)	Number of nozzles	Nozzle orifice diameter (mm)	Pipe conn. size	Spray capacity (L/min) [for reference only]										
				0.3 MPa	0.4 MPa	0.5 MPa	0.6 MPa	0.7 MPa	1.0 MPa	1.2 MPa	1.5 MPa	2.0 MPa	2.5 MPa	3.0 MPa
3-2L (ø3.5)	2	3.5	Rc1/2	23.4	27.0	30.2	33.1	35.7	42.7	46.8	—	—	—	—
3-2L (ø5.4)	2	5.4	Rc1/2	42.4	49.0	54.7	60.0	64.8	77.4	84.8	—	—	—	—
3-2S (ø1.8)	2	1.8	Rc1/2	—	—	—	—	—	11.8	—	14.5	16.7	18.7	20.4
3-2S (ø2.4)	2	2.4	Rc1/2	—	—	—	—	—	20.4	—	25.0	28.8	32.3	35.3
3-4S (ø1.8)	4	1.8	Rc1/2	—	—	—	—	—	23.6	—	28.9	33.4	37.3	40.9
3-4S (ø2.4)	4	2.4	Rc1/2	—	—	—	—	—	40	—	49.0	56.6	63.2	69.3

JA3 SERIES / JET ATTACKER / Powerful 3D Rotational Cleaning

Cleaning hard to remove dirt

Drawing

JA3-2L
(with 2 nozzles, low-pressure use)

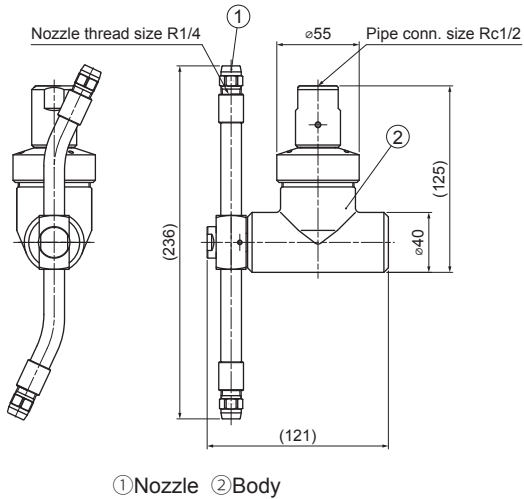

JA3-2S
(with 2 nozzles, medium-pressure use)

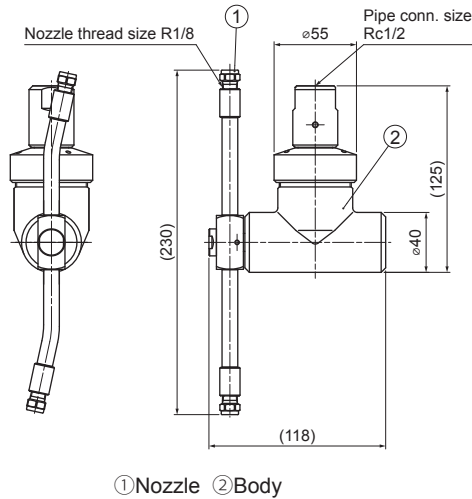

JA3-4S
(with 4 nozzles, medium-pressure use)

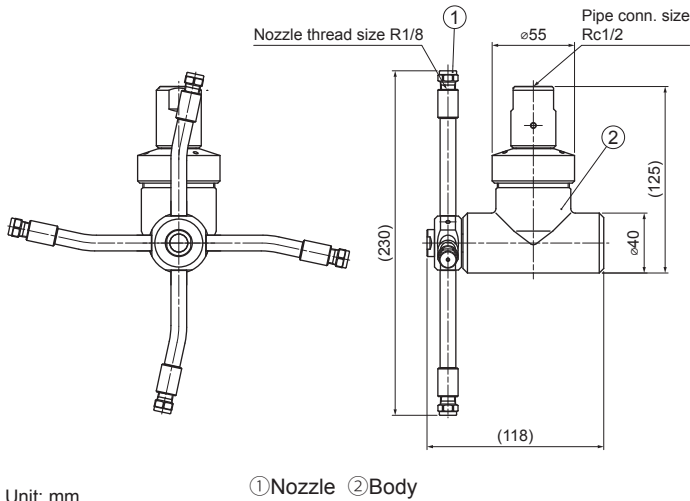

Unit: mm



Download 3D/2D CAD file

■ Dimensions and weight

Series	Nozzle orifice diameter (mm)	Pipe conn. size	Nozzle thread size	Weight (kg)
JA3-2L	3.5	Rc1/2	R1/4	1.70
	5.4			
JA3-2S	1.8	Rc1/2	R1/8	1.60
	2.4			
JA3-4S	1.8	Rc1/2	R1/8	1.95
	2.4			

Note:

For the insertion, the JA3-2L/2S requires a 125A hole or larger and the JA3-4S requires a 200A hole or larger.

HOW TO ORDER

To inquire about or order a specific product please refer to this coding system.

JA3-2L for low-pressure use

Example: 1/2F JA 3-2L (φ3.5) S304

1/2F^{*5} JA 3 - 2L (φ3.5) S304

Nozzle Orifice Diameter

- φ3.5
- φ5.4

JA3-2S/4S for medium-pressure use

Example: 1/2F JA 3-2S (φ1.8) S304

1/2F^{*5} JA 3 - 2 S (φ1.8) S304

Number of Nozzles

- 2
- 4

Nozzle Orifice Diameter

- φ1.8
- φ2.4

*5 "F" indicates female tapered pipe thread ("Rc" of the ISO standard), e.g. 1/2F = Rc1/2.

For cleaning hard to remove dirt

JET ATTACKER

JA3-D180 SERIES / 3D Rotational Cleaning, 180° Downward Spray

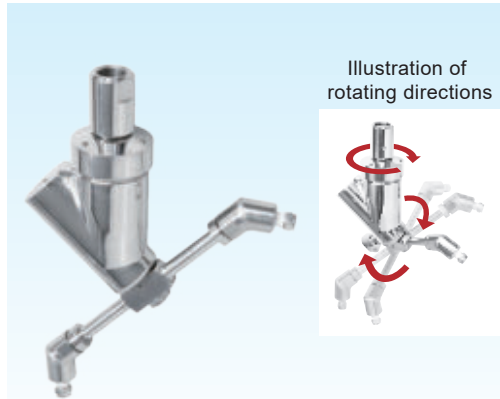

Spray Coverage

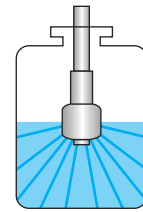

180° downward spray

Cleaning hard to remove dirt

Features

- Three-dimensional rotating solid stream jets powerfully clean the inside of a tank.
- No external power is needed as rotation is driven solely by the flow of the cleaning liquid.
- Easy to install, reducing equipment costs.
- The JA3-2S (D180) series is equipped with two nozzles, and the JA3-4S (D180) series with four nozzles.

Applications

- 180° downward spraying is ideal to clean inside of open-topped tanks and containers.

Basic Specifications

■ Operating Pressure Range
1.0–3.0 MPa (150–430 psi)

■ Spray Capacity²
JA3-2S (D180): 12–36 L/min
JA3-4S (D180): 24–70 L/min

■ Reach Distance of Spray (Diameter)
Approx. 6–9 m

■ Max. Temperature
60°C (140°F)

■ Number of Nozzles Attached
JA3-2S (D180) with two nozzles
JA3-4S (D180) with four nozzles

■ Main Material¹
S304, SCS14, S303, PTFE, FKM, S440C

■ Weight
JA3-2S (D180): 1.9 kg
JA3-4S (D180): 2.3 kg

■ Rotation Speed³
30–60 rpm

■ Outer Surface Finish
#320 buffing

¹In the material code, "S" represents "stainless steel". SCS14 is cast stainless steel equivalent to S316.

²Spray flow rate in the above operating pressure range is for reference only. See the flow-rate diagram and chart for more details.

³Set to this range of rotation speed at a pressure specified prior to shipping. The rotation speed varies depending on the applied pressure.

▼ Watch rotating & spraying nozzle on YouTube



IKEUCHI JA

JA3-D180 SERIES / JET ATTACKER / 3D Rotational Cleaning, 180° Downward Spray

Cleaning hard to remove dirt

- The liquid pressure and spray flow rate should be set based on your specific applications and requirements.
- Models available with two- and four-nozzles, with a nozzle orifice diameter of 1.8 or 2.4 mm.
- The operating pressure range is 1.0 to 3.0 MPa. When used at higher pressure, the rotation speed will become too high and the spray will become erratic.

Flow-rate Diagram

■ JA3-2S (D180) Series with 2 nozzles

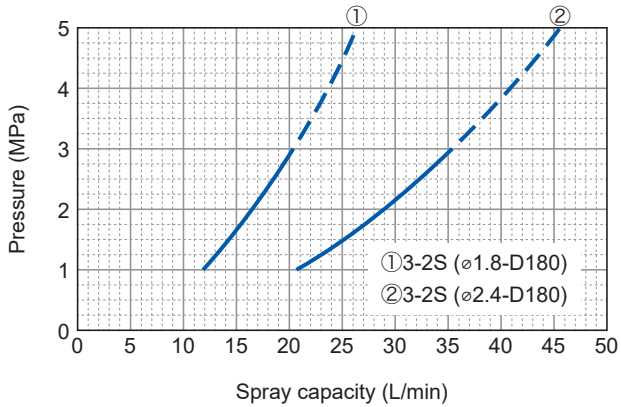

■ JA3-4S (D180) Series with 4 nozzles

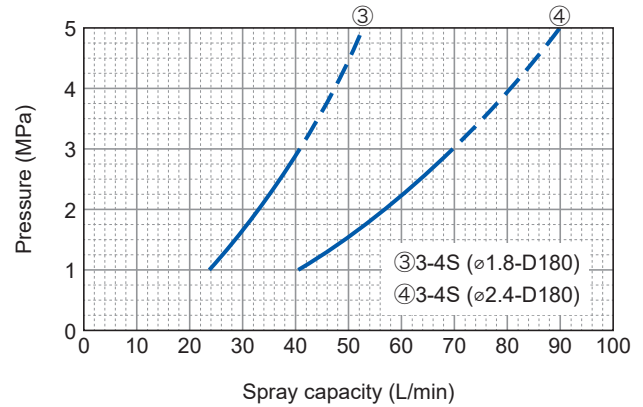

Flow-rate Chart

Model No. (JA...)	Number of nozzles	Nozzle orifice diameter (mm)	Pipe conn. size	Spray capacity (L/min) [for reference only]				
				1.0 MPa	1.5 MPa	2.0 MPa	2.5 MPa	3.0 MPa
3-2S (ø1.8-D180)	2	1.8	Rc1/2	11.8	14.5	16.7	18.7	20.4
3-2S (ø2.4-D180)	2	2.4	Rc1/2	20.4	25.0	28.8	32.3	35.3
3-4S (ø1.8-D180)	4	1.8	Rc1/2	23.6	28.9	33.4	37.3	40.9
3-4S (ø2.4-D180)	4	2.4	Rc1/2	40	49.0	56.6	63.2	69.3

JA3-D180 SERIES / JET ATTACKER / 3D Rotational Cleaning, 180° Downward Spray

Drawing

JA3-2S (D180)

(with 2 nozzles)

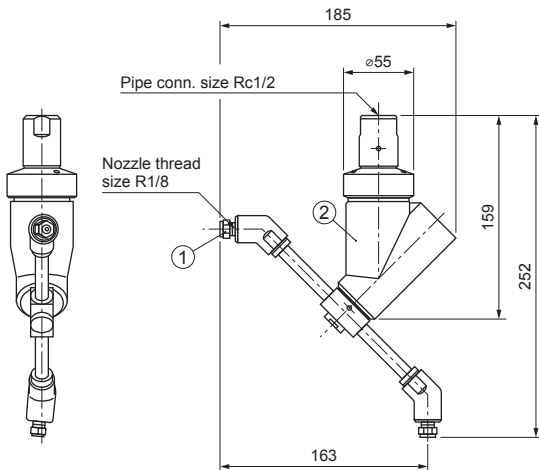

① Nozzle ② Body

JA3-4S (D180)

(with 4 nozzles)

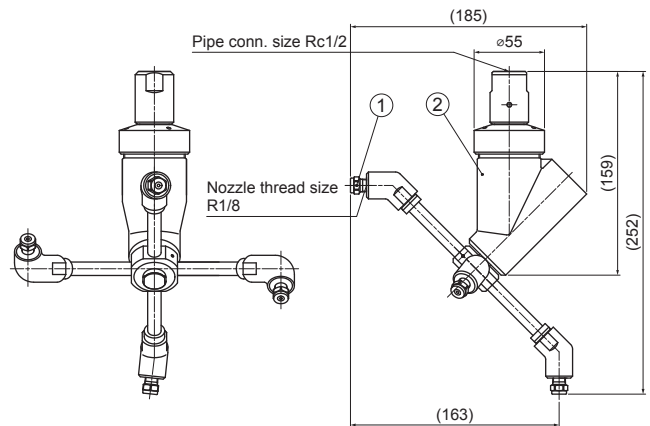

① Nozzle ② Body



Download 3D/2D CAD file

Unit: mm

■ Dimensions and weight

Series	Nozzle orifice diameter (mm)	Pipe conn. size	Nozzle thread size	Weight (kg)
JA3-2S (D180)	1.8	Rc1/2	R1/8	1.9
	2.4			
JA3-4S (D180)	1.8	Rc1/2	R1/8	2.3
	2.4			

Note:

For the insertion, the JA3-2S (D180) requires a 200A hole or larger and the JA3-4S (D180) requires a 250A hole or larger.

HOW TO ORDER

To inquire about or order a specific product please refer to this coding system.

Example: 1/2F JA 3-2S (ø1.8-D180) S304

1/2F^{*4} JA 3 - 2 S (ø1.8 - D180) S304

Number of Nozzles

- 2
- 4

Nozzle Orifice Diameter

- ø1.8
- ø2.4

*4 "F" indicates female tapered pipe thread ("Rc" of the ISO standard), e.g. 1/2F = Rc1/2.

For cleaning hard to remove dirt

JET ATTACKER

JA2 SERIES / Powerful 2D Rotational Cleaning



Cleaning hard to remove dirt



Spray Coverage

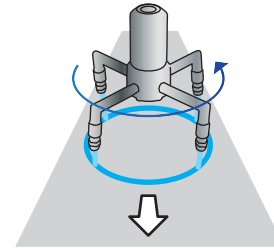

Spray downward

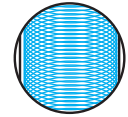

Cleaning pattern
(Patterns differ by line speeds)

Features

- The solid stream jet provides excellent cleaning performance. To achieve a wider spray coverage, a flat spray nozzle can be installed.
- No external power is needed as rotation is driven solely by the flow of the cleaning liquid.
- A variety of arm configurations are available as special order to fit specific cleaning needs, i.e. spot cleaning or full coverage cleaning.
- The JA2-2 series is equipped with two nozzles, and the JA2-4 series with four nozzles.
- Arm length can be tailored to your needs, in addition to the standard length of 200 or 300 mm.

Applications

- Cleaning of conveyor belts
- Cleaning of tanks and containers

Basic Specifications

Operating Pressure Range
0.3–2.0 MPa (45–290 psi)

Main Material¹
S304, S303, PTFE, FKM, S440C

Spray Capacity²
JA2-2: 14–136.8 L/min
JA2-4: 28–253.0 L/min

Weight
JA2-2: 1.9 kg
JA2-4: 2.0 kg

Max. Temperature
60°C (140°F)

Rotation Speed³
30–60 rpm

Number of Nozzles Attached
JA2-2 with two nozzles
JA2-4 with four nozzles

Outer Surface Finish
#320 buffing is optional and available upon request for an additional charge.

¹ In the material code, "S" represents "stainless steel".

² Estimated spray flow rate for JA2 series having solid stream nozzles with an orifice diameter of 2.5 mm, 3.5 mm, or 5.4 mm at the above range of operating pressure. See the flow-rate diagram and chart for details.

³ Set to this range of rotation speed at a pressure specified prior to shipping. The rotation speed varies depending on the applied pressure.

▼ Watch rotating & spraying nozzle on YouTube



IKEUCHI JA

Flow-rate Diagram

■ JA2-2 Series with 2 nozzles

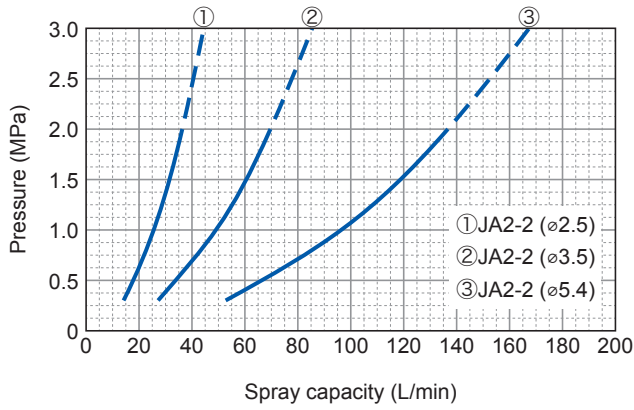

■ JA2-4 Series with 4 nozzles

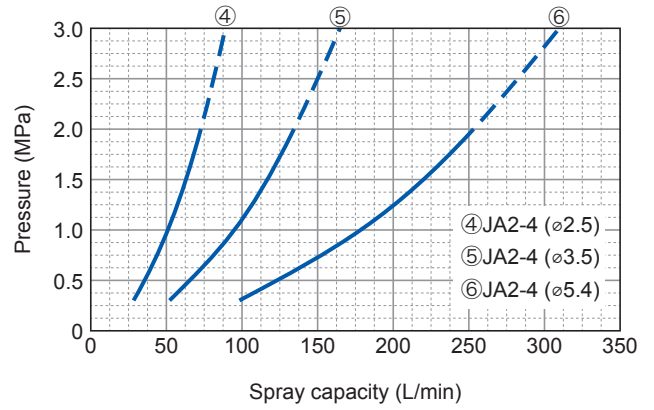

Flow-rate Chart

Model No.	Number of nozzles	Nozzle orifice diameter (mm)	Pipe conn. size	Spray capacity (L/min) [for reference only]								
				0.3 MPa	0.4 MPa	0.5 MPa	0.6 MPa	0.7 MPa	1.0 MPa	1.2 MPa	1.5 MPa	2.0 MPa
JA2-2 (ø2.5)	2	2.5	Rc1/2	14	16.2	18.1	19.8	21.4	25.6	28.0	31.3	36.1
JA2-2 (ø3.5)	2	3.5	Rc1/2	27	31.2	34.9	38.2	41.2	49.3	54.0	60.4	69.7
JA2-2 (ø5.4)	2	5.4	Rc1/2	53	61.2	68.4	75.0	81.0	96.8	106.0	118.5	136.8
JA2-4 (ø2.5)	4	2.5	Rc1/2	28	32.3	36.1	39.6	42.8	51.1	56.0	62.6	72.3
JA2-4 (ø3.5)	4	3.5	Rc1/2	52	60.0	67.1	73.5	79.4	94.9	104.0	116.3	134.3
JA2-4 (ø5.4)	4	5.4	Rc1/2	98	113.2	126.5	138.6	149.7	178.9	196.0	219.1	253.0

Cleaning hard to remove dirt

JA2 SERIES / JET ATTACKER / Powerful 2D Rotational Cleaning

Cleaning hard to remove dirt

Drawing



JA2-2
(with 2 nozzles)

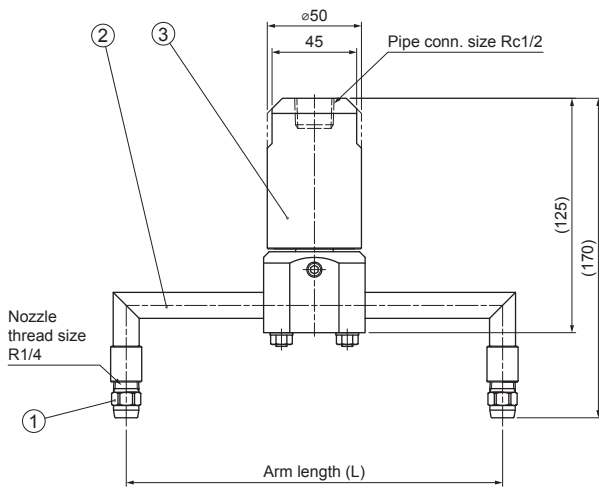

① Nozzle ② Arm ③ Body

JA2-4
(with 4 nozzles)

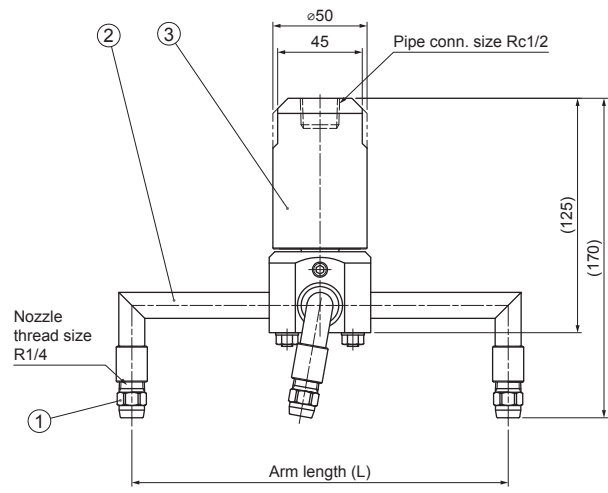

① Nozzle ② Arm ③ Body

Unit: mm

■ Dimensions and weight

Series	Nozzle orifice diameter (mm)	Pipe conn. size	Nozzle thread size	Arm length ^{*4} L (mm)
JA2-2	2.5	Rc1/2	R1/4	200
	3.5			300
	5.4			
JA2-4	2.5	Rc1/2	R1/4	200
	3.5			300
	5.4			

^{*4} Standard arm length is 200 mm or 300 mm. Customizable arm length from 200 mm to 1,500 mm. Contact us for details.

HOW TO ORDER

To inquire about or order a specific product please refer to this coding system.

Example: 1/2F JA 2-2 (ø2.5) S304 (L = 200)

1/2F^{*5} JA 2 - 2 (ø2.5) S304 (L = 200)

Number of Nozzles

■ 2

■ 4

Nozzle Orifice Diameter

■ ø2.5

■ ø3.5

■ ø5.4

Arm Length^{*4}

■ 200

■ 300

■ Desired length (up to 1,500 mm)

^{*5} "F" indicates female tapered pipe thread ("Rc" of the ISO standard), e.g. 1/2F = Rc1/2.

SWB SERIES / SHOWER BALL / Radial Spray from a Ball Nozzle

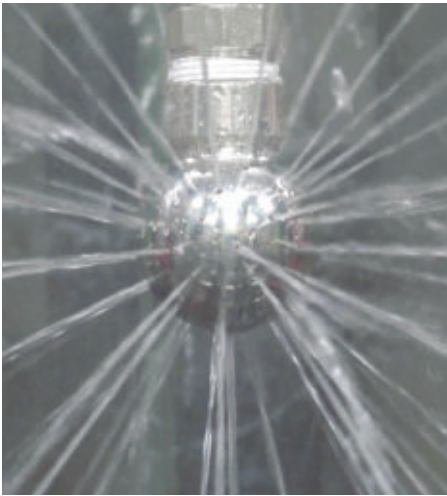

Also available in PTFE upon request. Contact us for details.

Spray Coverage

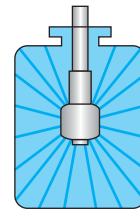

360° spray

Non-rotation nozzle

Features

- Simple structure.
- Two types of connections available, threaded or pinned.

Applications

- Cleaning the inside of a tank or other vessel

Basic Specifications

Operating Pressure Range
0.1–0.5 MPa (15–70 psi)

Spray Capacity²
35.4–395 L/min

Applicable Tank Size Diameter
About 450–3,750 mm

Max. Temperature⁴
400°C (752°F)

Material¹
S316L

Weight³
90–520 g

Outer Surface Finish
#320 buffing for threaded SWB series
#400 buffing for pinned SWB series

¹ In the material code, "S" represents "stainless steel".

² Spray flow rate in the above operating pressure range. See the flow-rate diagram and chart for details.

³ See the table in the drawing section.

⁴ 100°C (212°F) for SWB series made of PTFE.

▼ Watch spraying nozzle on YouTube



IKEUCHI SWB

Flow-rate Diagram

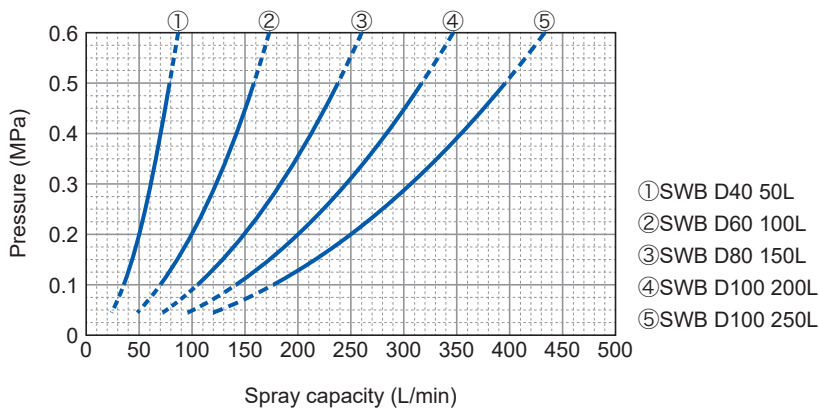

SWB SERIES / SHOWER BALL / Radial Spray from a Ball Nozzle

Flow-rate Chart

Ball diameter and spray capacity code	Nozzle orifice diameter (mm)	Pipe connection size		Suitable tank size diameter (mm)	Spray capacity (L/min)				
		Thread size	Pin size ⁵		0.1 MPa	0.2 MPa	0.3 MPa	0.4 MPa	0.5 MPa
D40 50L	1.2	Rc3/4	ø21	450– 900	35.4	50.0	61.2	70.7	79.1
D60 100L	1.7	Rc1	ø25	900–1,800	70.7	100	122	141	158
D80 150L	1.9	Rc1½	ø38	1,350–2,250	106	150	184	212	237
D100 200L	2.2	Rc2	ø50	1,800–3,000	141	200	245	283	316
D100 250L	2.4	Rc2	ø50	2,250–3,750	177	250	306	354	395

⁵Pin size indicates pin connection code, not the exact pin size or pipe diameter. For details see dimension table below.

Drawing

Thread Type

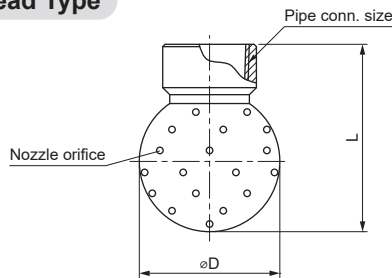

Pin Type

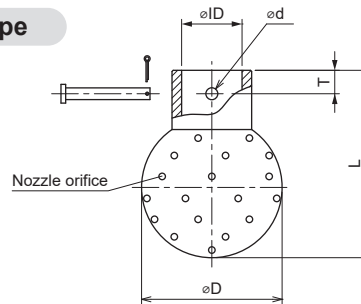

Download 3D/2D CAD file

■ Dimensions and weight

Ball diameter (øD) and spray capacity code	Pipe connection size		Outer dimensions (mm)					Number of orifices ⁶	Weight (g)
			L	øD	ød	øID	T		
D40 50L	Thread type	Rc3/4	56	40	–	–	–	44	90
	Pin type	15A (ø21.7)			5	22.1	10		
D60 100L	Thread type	Rc1	80	60	–	–	–	50	190
	Pin type	1S (ø25.4)			5	25.8	10		
D80 150L	Thread type	Rc1½	102	80	–	–	–	60	340
	Pin type	1.5S (ø38.1)			5	38.5	15		
D100 200L	Thread type	Rc2	125	100	–	–	–	60	520
	Pin type	2S (ø50.8)			8	51.2	15		
D100 250L	Thread type	Rc2	125	100	–	–	–	60	520
	Pin type	2S (ø50.8)			8	51.2	15		

⁶Drain hole is not included.

HOW TO ORDER

To inquire about or order a specific product please refer to this coding system.

Threaded SWB

Example: 3/4F SWB D40 50L S316L

3/4F SWB D40 50L S316L

Thread Size⁷

■3/4F ■1F
■1*1/2F ■2F

Ball Diameter and Spray Capacity Code

■D40 50L ■D60 100L
■D80 150L ■D100 200L
■D100 250L

Pinned SWB

Example: ø21 SWB D40 50L S316L

ø21 SWB D40 50L S316L

Pin Size⁵

■ø21 ■ø25
■ø38 ■ø50

Ball Diameter and Spray Capacity Code

■D40 50L ■D60 100L
■D80 150L ■D100 200L
■D100 250L

⁷"F" indicates female tapered pipe thread ("Rc" of the ISO standard), e.g. 3/4F = Rc3/4.

RJ2-PON SERIES / Pressure-open Nozzle with Self-retracting Tip

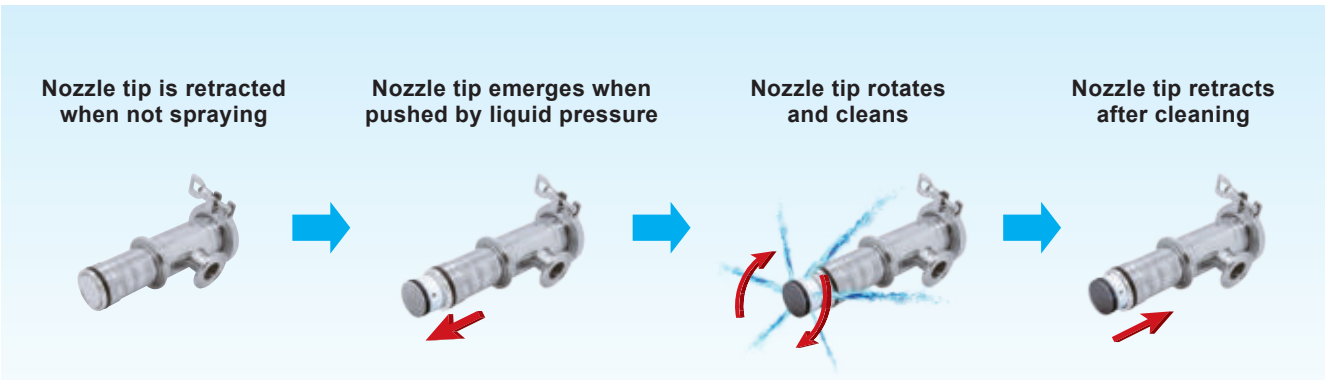

Features

- Pressurized liquid pushes this unique nozzle tip open and it automatically retracts when the liquid pressure stops.
- Powerfully cleans the inside of ducts and tanks.
- Suitable for permanent installation as the nozzle closes flush with the inside surface of the duct or tank when not cleaning.
- Easy to install and remove with ferrule.
- No external power is needed as rotation is driven solely by the flow of the cleaning liquid.

Applications

- Duct cleaning
- Tank cleaning

▼ Watch rotating & spraying nozzle on YouTube

IKEUCHI RJ2-PON

Basic Specifications

<ul style="list-style-type: none"> ■ Operating Pressure Range 0.2–0.5 MPa (30–70 psi) ■ Spray Capacity¹ RJ2-PON40: 33.1–50.2 L/min RJ2-PON60: 49.7–75.3 L/min RJ2-PON80: 66.3–100.4 L/min ■ Reach Distance of Spray (L) 4,000–5,000 mm ■ Spreading Angle (θ) 40° ■ Spreading Width (W) 1,600–2,100 mm 	<ul style="list-style-type: none"> ■ Max. Temperature 80°C (176°F) ■ Material^{2, 3} S304, PTFE, FKM, silicon rubber ■ Weight 1.3 kg ■ Rotation Speed About 170 rpm (for reference only) ■ Chemical Resistance Weak acid/alkaline 3% or less
---	---

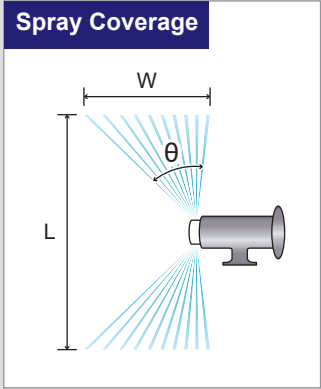

¹ Spray flow rate in the above operating pressure range is for reference only. See the flow-rate diagram and chart for more details.

² In the material code, "S" represents "stainless steel".

³ See the table in the drawing section on page 38.

RJ2-PON SERIES / Pressure-open Nozzle with Self-retracting Tip

Example of Use

Duct Cleaning

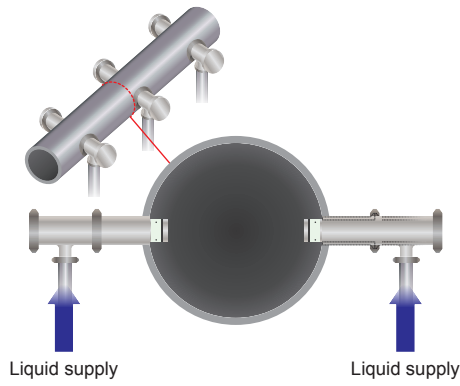

Tank Cleaning

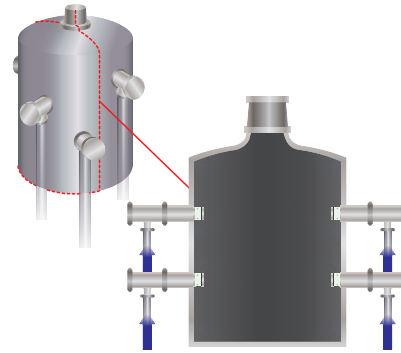

Note: Image shows RJ2-PON nozzles with nozzle tips opened by pressurized cleaning liquid.

Flow-rate Diagram

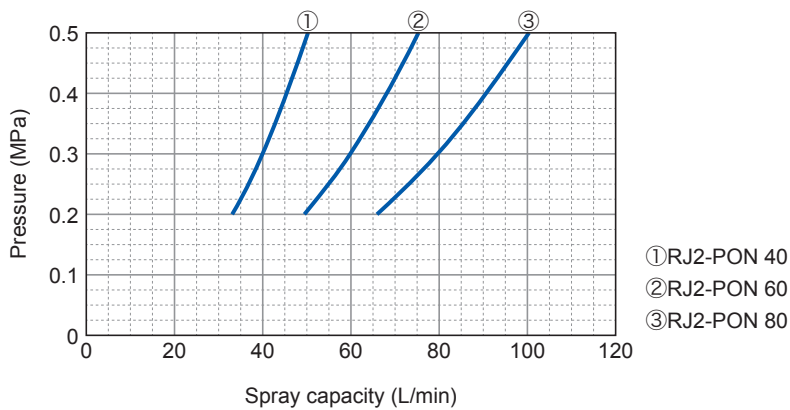

Flow-rate Chart

Spray capacity code	Spray capacity (L/min) [for reference only]						
	0.2 MPa	0.25 MPa	0.3 MPa	0.35 MPa	0.4 MPa	0.45 MPa	0.5 MPa
40	33.1	36.7	40.0	42.8	45.5	47.9	50.2
60	49.7	55.1	60.0	64.3	68.2	71.8	75.3
80	66.3	73.5	80.0	85.7	90.9	95.8	100.4

RJ2-PON SERIES / Pressure-open Nozzle with Self-retracting Tip

Drawing

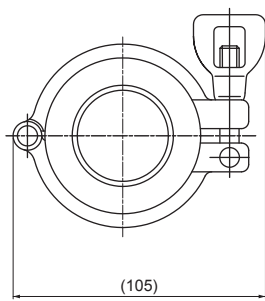

Unit: mm

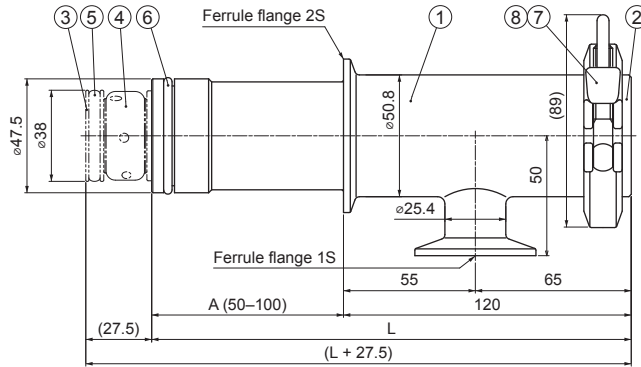

Components	Material ²
① Nozzle body	S304
② Ferrule cap (2S)	S304
③ Shaft	S304
④ Nozzle tip (rotating part)	PTFE
⑤ O-ring (P32)	FKM
⑥ O-ring (P41)	FKM
⑦ Ferrule gasket (2S)	Silicon rubber
⑧ Clamp (CP2K 2S)	S304

Note: Short pipe, ferrule flange and clamp which are required for the installation in a tank are to be supplied by customer.

Comparison of Spray Impact

Measuring Conditions

Measuring method	Pressure indicating film ⁴
Distance from nozzle orifice to film	600 mm
Type of pressure indicating film	5LW (ultra extreme low pressure)
Spray pressure	0.3 MPa

⁴A pressure-sensitive sensor film that quickly reveals surface contact distribution and magnitude of pressure on its entire surface. Red patches appear on the film and the color density indicated varies according to the differing contact pressure levels.

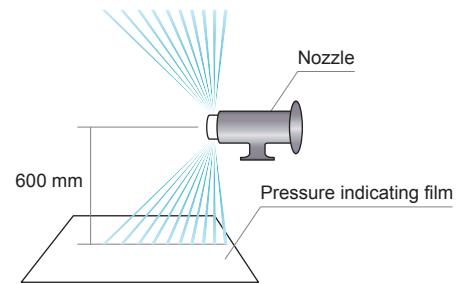

Measurement Results

IKEUCHI's nozzle (RJ2-PON)

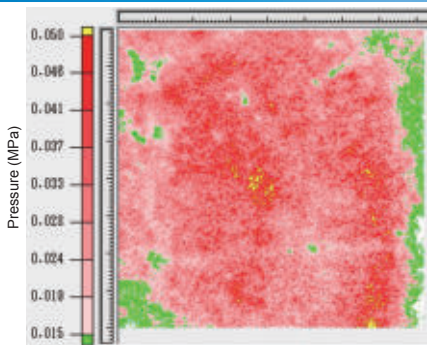

Nozzle from another supplier

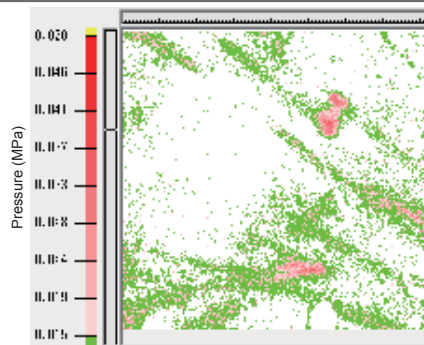

Compared with a nozzle from another supplier, IKEUCHI's RJ2-PON series provides **higher pressure over the entire surface**, resulting in **higher cleaning power!**

HOW TO ORDER

To inquire about or order a specific product please refer to this coding system.

Example: RJ2-PON 80-1S × 80 S304

RJ2-PON 80 - 1S × 80 S304

Spray Capacity Code

- 40
- 60
- 80

Insertion Length (A)⁵

- 50-100

⁵ See dimension A in drawing.

Automatic Nozzle Lifting System

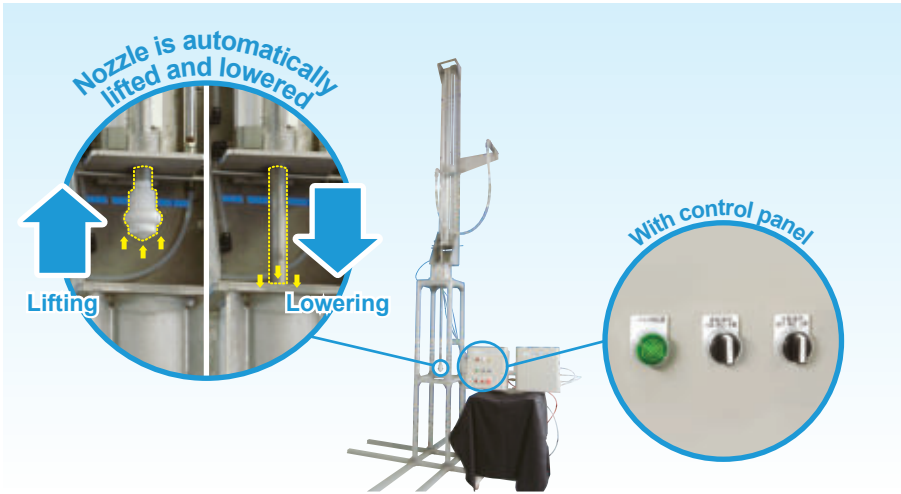

Features

- Lifting device able to move up and down a spray nozzle attached on the tip with compressed air.
- The maximum stroke of about 1.7 m allows for cleaning tall tanks.

Unit Components

This system has the following components:

- Lifting device
- Electric control panel
- Spray nozzle (ES or SR series)
- Pneumatic control panel
- Accessories (tubing)
- Isolation valve (optional)

Contact us for more details.

Basic Specifications

Lifting Device

Power Supply Voltage
100–240 VAC

Operating Pressure Range
0.3–0.7 MPa (45–100 psi) for air
0.05–1.0 MPa (8–145 psi) for liquid

Operating Temperature Range
5–50°C (41–122°F)

Weight
Approx. 90 kg²

Main Material¹

Liquid contact parts: S304, fluorocarbon resin
The other parts: S304, aluminum

Lift Mechanism

- Driven by compressed air
- Stroke range from 500 mm to about 1,700 mm³
- Lift speed of about 100 mm/s
- Rodless cylinder with brake
- Limit switches to detect the nozzle position

Control Panels

Power Supply Voltage
100–240 VAC (50/60 Hz)

Operating Temperature Range
5–50°C (41–122°F)

Weight

Electric control panel: about 6 kg
Pneumatic control panel: about 5 kg

¹In the material code, "S" represents "stainless steel".

²Based on a flange of 100A and cylinder stroke of 1,700 mm. Contact us for other available sizes.

³Stroke length varies depending on the nozzles used with the device.

Automatic Nozzle Lifting System

System Flow

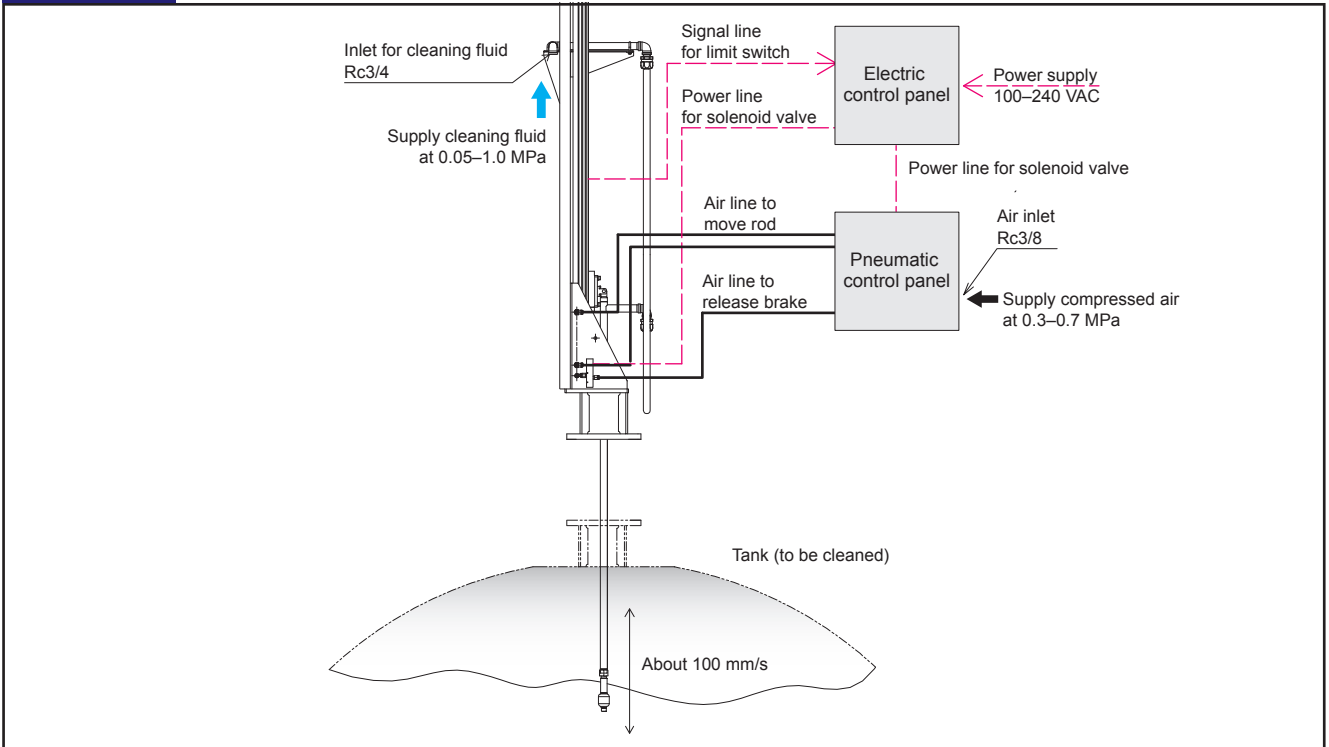

Drawing of Lifting Device

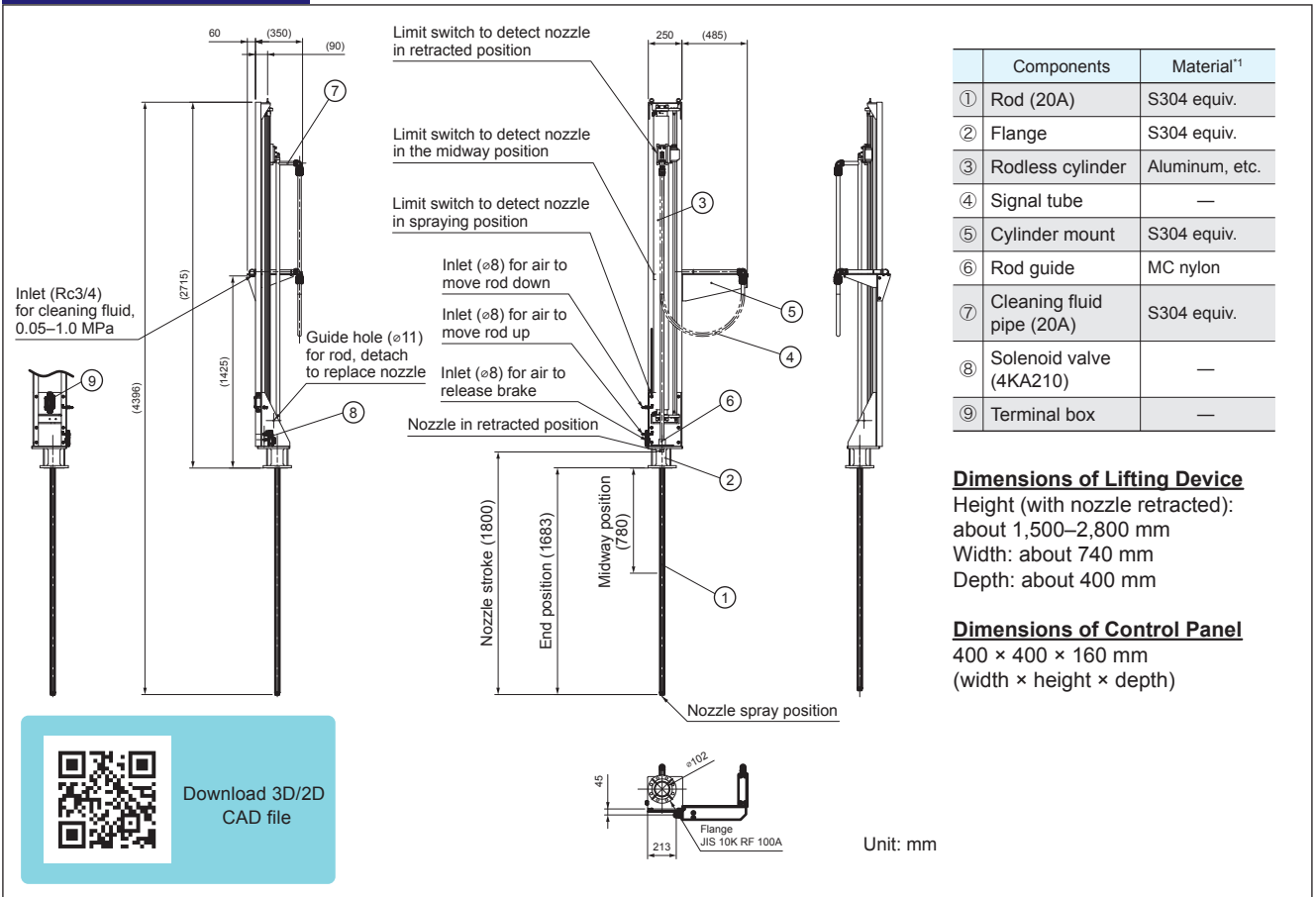

Download 3D/2D CAD file

FAQ Frequently Asked Questions

Q. Is it possible to use a rotating nozzle with air instead of liquid?

A. We do not recommend it. Our rotating nozzles may not operate normally and could cause malfunctions. They are designed to be used with liquid. Contact us with the specific application for use requiring supply of air instead of liquid.

Q. Is it possible to specify a rotation speed?

A. It is not possible to set a specific rotation speed. Many of our rotating nozzle series are shipped after being adjusted to a rotation speed in the design range.

Q. What should be done to prevent clogging?

A. Please flush the pipe system thoroughly before installing the nozzle and install a strainer to prevent the nozzle from clogging. See "Clog Prevention (Strainer and Flushing the Piping)" on page 4 for details.

Please feel free to contact us for custom-made products and any other questions.

Videos with English Subtitles

Discover our educational videos with English subtitles, designed to help you choose the right tank cleaning nozzle. Stay tuned for more videos to come.

How to Choose the Right Cleaning Nozzle for Different Types of Dirt?	Comparing the Cleaning Power of Tank Cleaning Nozzles	Tank Cleaning Nozzle Series Comparison: SR vs ES
		

Description of Thread Size and Type

Threads noted in this catalog are tapered pipe threads unless otherwise specified. The connection thread size and type are described according to the ISO standard. When ordering our nozzles, please specify the thread size using our thread code as shown on the right. For mixed fractions, our thread size code inserts "*" after the whole number. For example, 1*1/4M stands for R1 1/4.

Thread type	ISO standard	British standard	Our thread code
Male tapered pipe threads	R1/4	1/4 BSPT male	1/4M
Female tapered pipe threads	Rc1/4	1/4 BSPT female	1/4F

Note: Specifications of the products and contents of this catalog are subject to change without prior notice for purpose of product improvement.

Reference Data

■ Conversion of Units

Length	μm	mm	cm	m	in	ft
	1	1×10 ³	1×10 ⁻⁴	1×10 ⁻⁶	3.94×10 ⁻⁵	3.28×10 ⁻⁶
	1×10 ³	1	0.1	1×10 ⁻³	3.94×10 ⁻²	3.28×10 ⁻³
	1×10 ⁴	10	1	1×10 ⁻²	3.94×10 ⁻¹	3.28×10 ⁻²
	1×10 ⁶	1×10 ³	100	1	3.94×10	3.28
	2.54×10 ⁴	25.4	2.54	2.54×10 ⁻²	1	8.33×10 ⁻²
	3.05×10 ⁵	3.05×10 ²	3.05×10	3.05×10 ⁻¹	12	1

Viscosity	1 P = 100 cP 1 St = 100 cSt
Weight	1 kg ≈ 2.21 lb 1 lb ≈ 0.454 kg
Temperature	[°F] ≈ ([°C] × 9/5) + 32 [°C] ≈ 5/9 ([°F] - 32)

Area	cm ²	m ²	in ²	ft ²
	1	1×10 ⁻⁴	0.155	1.08×10 ⁻³
	1×10 ⁴	1	1.55×10 ³	10.8
	6.45	6.45×10 ⁻⁴	1	6.94×10 ⁻³
	9.30×10 ²	9.30×10 ⁻²	1.44×10 ²	1

■ Water flow rate and proper pipe size

Nominal size		Steel pipe		Flow rate (L/min) when pressure loss is 0.01–0.03MPa per pipe length of 10 m
A	B	Inside dia. (mm)	Outside dia. (mm)	
6A	1/8B	6.5	10.5	1.3–2.2
8A	1/4B	9.2	13.8	3–5.2
10A	3/8B	12.7	17.3	7–12
15A	1/2B	16.1	21.7	12–21
20A	3/4B	21.6	27.2	22–38
25A	1B	27.6	34.0	38–65
32A	1¼B	35.7	42.7	70–120
40A	1½B	41.6	48.6	120–210
50A	2B	52.9	60.5	215–370
65A	2½B	67.9	76.3	410–700
80A	3B	80.7	89.1	680–1,200
100A	4B	105.3	114.3	1,200–2,100
125A	5B	130.8	139.8	2,100–3,600
150A	6B	155.2	165.2	3,300–5,700

Volume	cm ³	L (Liter)	m ³ (kL)	ft ³	imperial gal.	U.S. gal.
	1	1×10 ⁻³	1×10 ⁻⁶	3.53×10 ⁻⁵	2.2×10 ⁻⁴	2.64×10 ⁻⁴
	1×10 ³	1	1×10 ⁻³	3.53×10 ⁻²	0.220	0.264
	1×10 ⁶	1×10 ³	1	353	220	264
	2.83×10 ⁴	28.3	2.83×10 ⁻²	1	6.23	7.48
	4.55×10 ³	4.55	4.55×10 ⁻³	0.16	1	1.2
	3.79×10 ³	3.79	3.79×10 ⁻³	0.134	0.833	1

Pressure	MPa	bar	kg/cm ²	psi (lb/in ²)	atm	mmHg	mmH ₂ O (mmAq)
	1	10	10.2	145	9.87	7.5×10 ³	1.02×10 ⁵
	0.1	1	1.02	14.5	0.987	750	1.02×10 ⁴
	0.098	0.981	1	14.2	0.968	736	1×10 ⁴
	6.89×10 ⁻³	0.069	0.070	1	0.068	51.7	703
	0.101	1.01	1.03	14.7	1	760	1.03×10 ⁴
	1.33×10 ⁻⁴	1.33×10 ⁻³	1.36×10 ⁻³	0.019	1.32×10 ⁻³	1	13.6
	9.81×10 ⁻⁶	9.81×10 ⁻⁵	1×10 ⁻⁴	1.42×10 ⁻³	9.68×10 ⁻⁵	0.074	1

Flow rate	L/min	m ³ /min	m ³ /hr	in ³ /hr	ft ³ /hr	Imperial gal./min	U.S. gal./min
	1	1×10 ⁻³	0.06	3.66×10 ³	2.12	0.22	0.264
	1×10 ³	1	60	3.66×10 ⁶	2.12×10 ³	220	264
	16.7	0.017	1	6.10×10 ⁴	35.3	3.67	4.40
	2.73×10 ⁻⁴	2.7×10 ⁻⁷	1.64×10 ⁻⁵	1	5.79×10 ⁻⁴	6.01×10 ⁻⁵	7.22×10 ⁻⁵
	0.472	4.72×10 ⁻⁴	0.028	1.73×10 ³	1	0.104	0.125
	4.55	4.55×10 ⁻³	0.273	1.66×10 ⁴	9.63	1	1.20
	3.79	3.79×10 ⁻³	0.227	1.39×10 ⁴	8.02	0.833	1



“The Fog Engineers”
H. IKEUCHI & CO., LTD.



ISO9001: 2015 certified
(H. IKEUCHI & CO., LTD., Japan only)



Headquarters

Daiichi kyogyo Bldg., 1-15-15, Awaza, Nishi-ku, Osaka 550-0011, Japan

Tel: 81-6-6538-4015 Fax: 81-6-6538-4022

Email: overseas@kirinoikeuchi.co.jp

URL: <https://www.kirinoikeuchi.co.jp/eng/>

Overseas network

IKEUCHI USA, INC.

4722 Ritter Avenue, Blue Ash, OH 45242, USA
Tel: 1-513-942-3060 Fax: 1-513-942-3064
info@ikeuchi.us
<https://www.ikeuchi.us/>

PT. IKEUCHI INDONESIA

Ruko Rodeo Drive, Jl. Hollywood Boulevard Blok B6 No. 18 & 19,
Jababeka, Bekasi, Jawa Barat 17530 Indonesia
Tel: 62-21-8938-4201 (or 4202)
sales@ikeuchi.id
<https://www.ikeuchi.id/>

IKEUCHI (SHANGHAI) CO., LTD.

Room C, 21F, Electrical & Mechanical Bldg.,
600 Hengfeng Road, Shanghai 200070, P.R.China
Tel: 86-21-6140-9731
mist@kirinoikeuchi.com
<http://www.kirinoikeuchi.com/>

Tianjin Branch Tel: 86-22-2320-1676
Shenzhen Branch Tel: 86-755-8525-2221
Wuhan Branch Tel: 86-27-8558-8299

IKEUCHI EUROPE B.V.

Merwedeweg 6, 3621 LR, Breukelen, The Netherlands
Tel: 31-20-820-2175
info@ikeuchi.eu
<https://www.ikeuchi.eu/>

SIAM IKEUCHI CO., LTD.

909 Ample Tower Bldg. 8FL., Unit 8/2, 8/3, Debaratana Road,
Bangna Nuea, Bangna, Bangkok 10260 Thailand
Tel: 66-2-348-3801 Fax: 66-2-348-3802
thai@ikeuchi.co.th
<https://www.ikeuchi.co.th/>

IKEUCHI TAIWAN CO., LTD.

11F-1, No.27, Sec.1, Chung Shan N. Road, Taipei 10441,
Taiwan, R.O.C.
Tel: 886-2-2511-6289 Fax: 886-2-2541-6392
sales@ikeuchi.com.tw
<http://www.ikeuchi.com.tw/>