

# Large Capacity Fine Fog Nozzles

## GSIM II

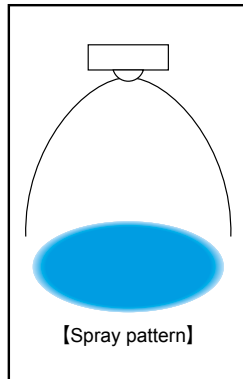
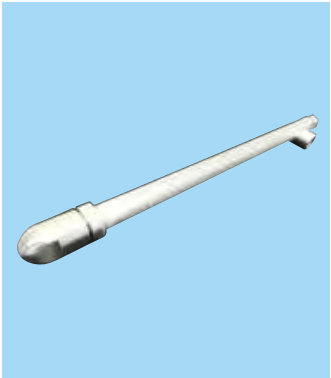

- Pneumatic spray nozzle producing fine atomization with a mean droplet diameter of 50 μm and a max. droplet diameter of 150 μm at an air-water ratio of 130.\*1
  - Energy-saving design that provides large amount of "fine fog" with smaller air consumption, yielding a spray capacity of 30–1,000 L/hr at an air-water ratio of 130.
  - Available in spray angles of 60° and 20°, in 6 spray capacity types—12 varieties in total. Wide selection.
  - Easy maintenance with simple structure and compact body.
- \*1) Droplet diameter measured by laser Doppler method

### APPLICATIONS

- Cooling: Gas, moldings, refractories
- Moisture control: Flue gas, concrete
- Combustion: Oil, waste fluid
- Dust suppression: Recycling facilities, material facilities, moldings

## GSIM II Nozzle with T-type Adaptor

### DRAWING

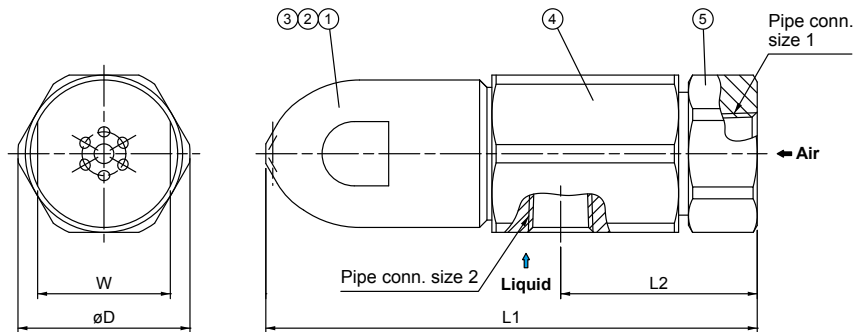

Note: The above drawing is for GSIM6037IIS316L+TS303.  
Configurations of nozzle tip slightly differ depending on air consumption codes.

### COMPONENTS AND MATERIALS

No.	Components	Standard materials	No.	Components	Standard materials
1	Nozzle tip	S316L	4	Adaptor	S303
2	Nozzle core	S316L	5	Air socket	S303
3	Whirler	S316L equivalent			

### DIMENSIONS

Spray angle code	Air consumption code	Pipe connection size		Outer dimensions (mm)				Free passage diameter (mm)		Mass (g)
		1 (Air)	2 (Liquid)	L1	L2	W	øD	Air	Liquid*2	
60 20	37	Rc3/8	Rc1/4	100	40	27	35	1.6	1.8 (2.2)	500
	55							2.0	2.2 (2.2)	
	75	Rc1/2	Rc3/8	120	42	32	45	2.3	2.6 (3.2)	900
	110							2.9	3.2 (3.2)	
	150	Rc3/4	Rc1/2	140	44	46	50	3.3	3.7 (4.0)	1,200
	220							4.0	4.0 (4.0)	

\*2) Free passage diameter in ( ) shows that of GSIM II with spray angle code of 20.

### HOW TO ORDER

Please inquire or order for a specific nozzle using this coding system.

<Example> GSIM6037II S316L + T S303

GSIM	<b>60</b>	<b>37</b>	II	<b>S316L</b>	+	<b>T</b>	<b>S303</b>
	Spray angle code	Air consumption code		Material of nozzle tip		Type of adaptor	Material of adaptor
	■60	■37					
	■20	■75					
		■110					
		■150					
		■220					

## Flange Type

### DRAWING

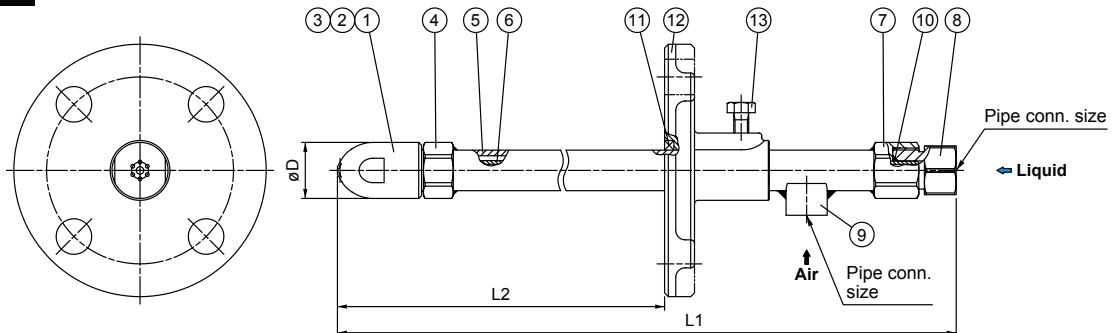

### COMPONENTS AND MATERIALS

No.	Components	Standard materials	No.	Components	Standard materials
1	Nozzle tip	S316L	7	Joint	S304
2	Nozzle core	S316L	8	Liquid socket	S304
3	Whirler	S316L equivalent	9	Air socket	S304
4	Nozzle adaptor	S316L	10	O-ring	FKM
5	Outer pipe (for air)	S316L	11	Packing	Metal wire reinforced AES wool
6	Inner pipe (for liquid)	S304	12	Flange	SCS13 (S304)
			13	Bolt	S304

### DIMENSIONS

Spray angle code	Air consumption code	Pipe connection size		Outer diameter $\varnothing$ D (mm)	Free passage diameter (mm)	
		Air	Liquid		Air	Liquid*2
60 20	37	Rc3/8	Rc3/8	30	1.6	1.8 (2.2)
	55				2.0	2.2 (2.2)
	75	Rc1/2	Rc1/2	38	2.3	2.6 (3.2)
	110				2.9	3.2 (3.2)
	150	Rc3/4	Rc3/4	50	3.3	3.7 (4.0)
	220				4.0	4.0 (4.0)

\*2) Free passage diameter in ( ) shows that of GSIM II with spray angle code of 20.

### TYPE OF LENGTH

Type	Total length L1*3 (mm)	Length L2 (mm)
A	560	300–400
B	760	400–600
C	960	600–800
D	1,160	800–1,000

\*3) L1: Standard length

### MASS

Air consumption code	Type of length	Mass*4 (g)
37, 55	A	1,300
	B	1,600
	C	2,000
	D	2,400
75, 110	A	1,800
	B	2,300
	C	2,800
	D	3,300
150, 220	A	2,500
	B	3,100
	C	3,700
	D	4,300

\*4) The mass shown is when the total length is the standard length L1 and excludes a mass of flange. For longer lengths, add the corresponding mass for each 100 mm of L1 length as below.

(Air consumption code: Mass per 100 mm)  
37/55: 180 g,  
75/110: 260 g,  
150/220: 300 g

# Large Capacity Fine Fog Nozzles GSIM II series

## FLOW-RATE DIAGRAMS SPRAY ANGLE 60° TYPE

- How to read the chart
- 1. The spray capacity shown is for one nozzle.
- 2. **Red lines** (—) represent compressed air pressures  $P_a$  in MPa.  
**Blue lines** (—) represent liquid pressures  $P_w$  in MPa.  
**Green lines** (—) represent air-water ratio  $Q_a/Q_w$ .
- 3. Figures in ovals  $\bigcirc$  indicate Sauter mean diameters ( $\mu\text{m}$ ) measured by laser Doppler method.

■ GSIM6037 II

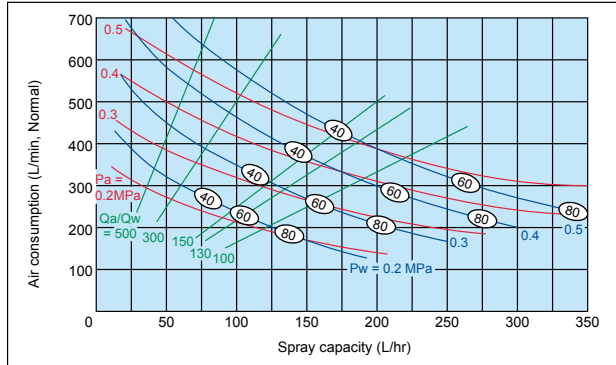

■ GSIM6055 II

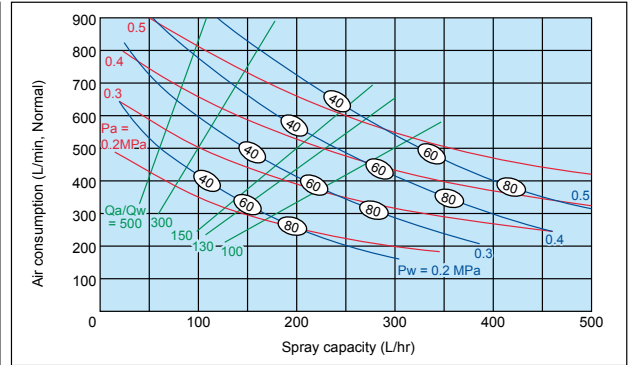

■ GSIM6075 II

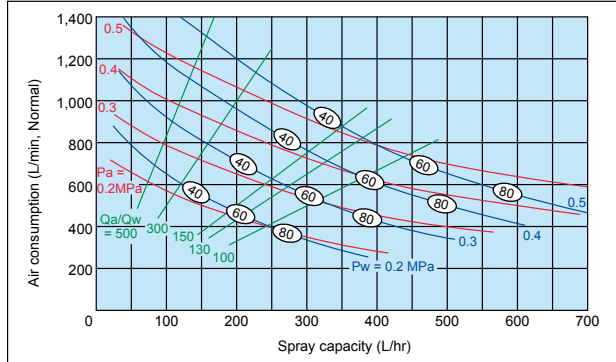

■ GSIM60110 II

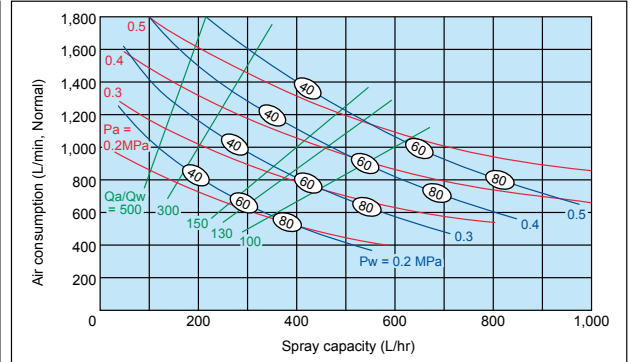

■ GSIM60150 II

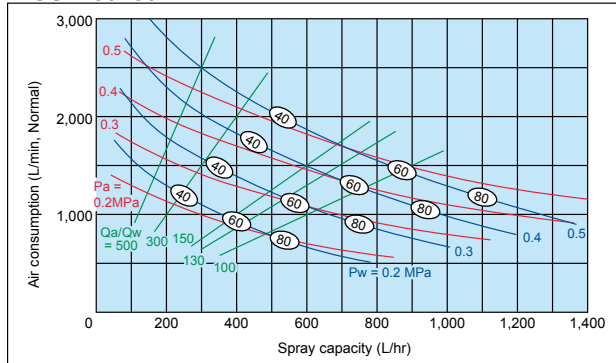

■ GSIM60220 II

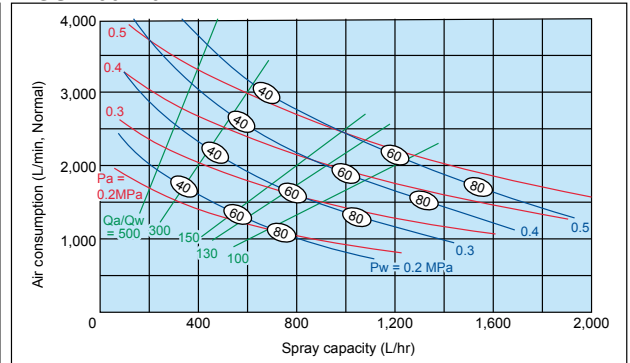

GSIM II

**FLOW-RATE DIAGRAMS**

**SPRAY ANGLE 20° TYPE**

■ How to read the chart

1. The spray capacity shown is for one nozzle.
2. **Red lines** (—) represent compressed air pressures  $P_a$  in MPa.  
**Blue lines** (—) represent liquid pressures  $P_w$  in MPa.  
**Green lines** (—) represent air-water ratio  $Q_a/Q_w$ .
3. Figures in ovals  $\bigcirc$  indicate Sauter mean diameters ( $\mu\text{m}$ ) measured by laser Doppler method.

■ **GSIM2037 II**

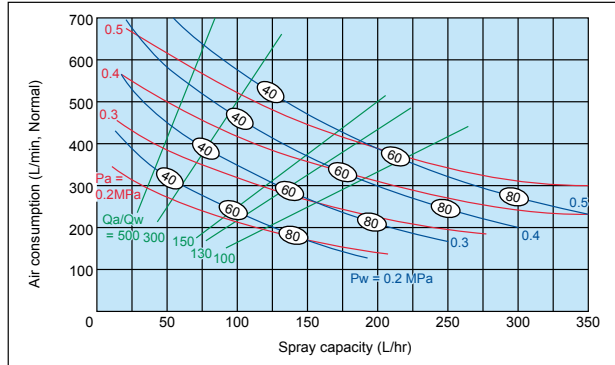

■ **GSIM2055 II**

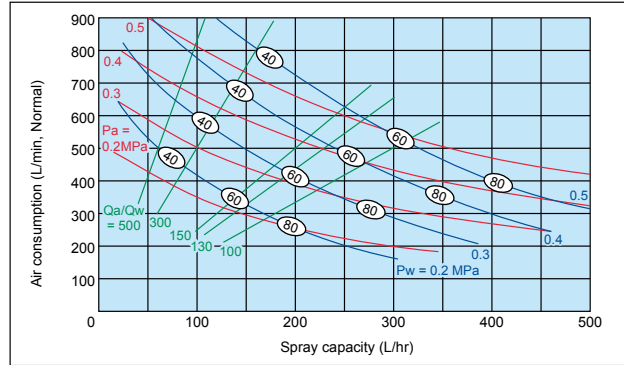

■ **GSIM2075 II**

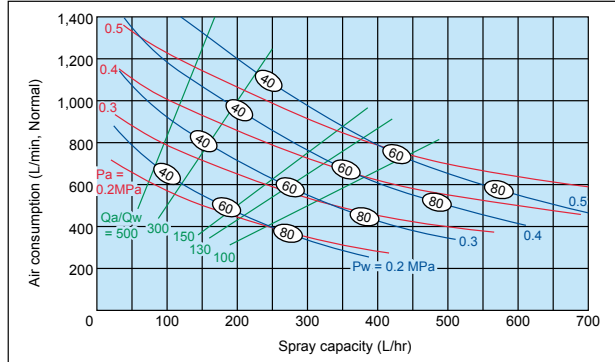

■ **GSIM20110 II**

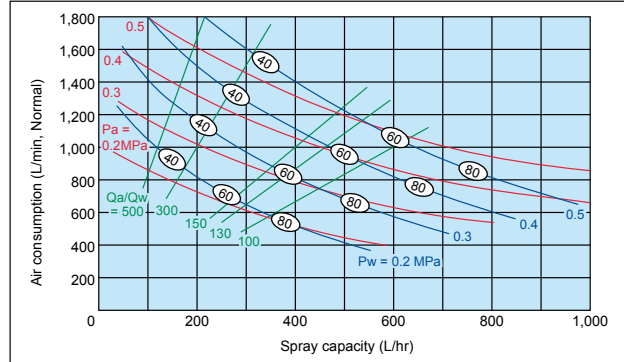

■ **GSIM20150 II**

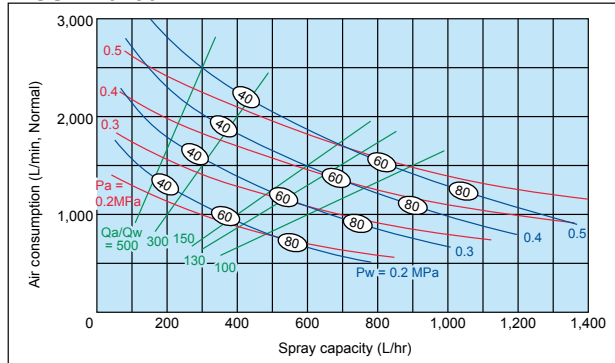

■ **GSIM20220 II**

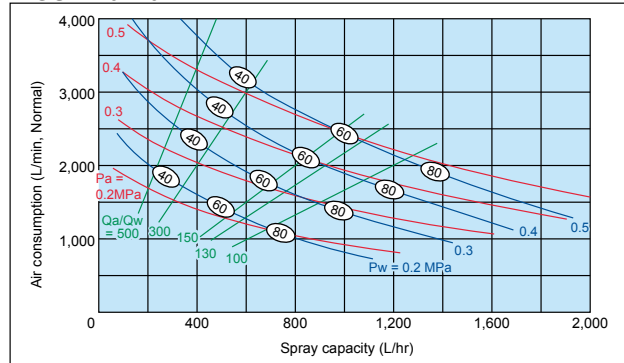

GSIM II

# Large Capacity Fine Fog Nozzles GSIM II series

## SPRAY DIMENSIONS

### ■ Spray angle code: 60

Air consumption code	Air pressure (MPa)	Liquid pressure (MPa)	Spray dimensions (mm)				
			D1	D2	D3	D4	L
37	0.3	0.25-0.30	600	950	1,200	1,700	8,000
		0.30-0.35	700	1,050	1,350	1,700	8,000
	0.4	0.35-0.40	550	850	1,100	1,700	8,000
		0.40-0.45	650	950	1,250	1,700	8,000
	0.5	0.45-0.50	500	800	1,000	1,700	8,000
		0.50-0.55	600	900	1,150	1,700	8,000
55	0.3	0.25-0.30	650	1,000	1,250	1,800	9,000
		0.30-0.35	750	1,100	1,400	1,800	9,000
	0.4	0.35-0.40	600	900	1,150	1,800	9,000
		0.40-0.45	650	1,000	1,300	1,800	9,000
	0.5	0.45-0.50	500	850	1,050	1,800	9,000
		0.50-0.55	600	950	1,200	1,800	9,000
75	0.3	0.25-0.30	700	1,050	1,300	1,900	10,000
		0.30-0.35	800	1,150	1,450	1,900	10,000
	0.4	0.35-0.40	650	950	1,200	1,900	10,000
		0.40-0.45	700	1,050	1,350	1,900	10,000
	0.5	0.45-0.50	550	900	1,100	1,900	10,000
		0.50-0.55	600	1,000	1,250	1,900	10,000
110	0.3	0.25-0.30	750	1,100	1,400	1,900	10,000
		0.30-0.35	850	1,200	1,500	1,900	10,000
	0.4	0.35-0.40	700	1,050	1,300	1,900	11,000
		0.40-0.45	750	1,150	1,450	1,900	11,000
	0.5	0.45-0.50	600	1,000	1,200	1,900	11,000
		0.50-0.55	650	1,100	1,350	1,900	11,000
150	0.3	0.25-0.30	800	1,150	1,500	2,000	11,000
		0.30-0.35	900	1,250	1,600	2,000	11,000
	0.4	0.35-0.40	750	1,100	1,400	2,000	12,000
		0.40-0.45	800	1,200	1,500	2,000	12,000
	0.5	0.45-0.50	650	1,050	1,300	2,000	12,000
		0.50-0.55	700	1,150	1,400	2,000	12,000
220	0.3	0.25-0.30	900	1,200	1,600	2,100	11,000
		0.30-0.35	950	1,300	1,700	2,100	11,000
	0.4	0.35-0.40	800	1,150	1,500	2,100	12,000
		0.40-0.45	850	1,250	1,600	2,100	12,000
	0.5	0.45-0.50	700	1,100	1,400	2,100	12,000
		0.50-0.55	750	1,200	1,500	2,100	12,000

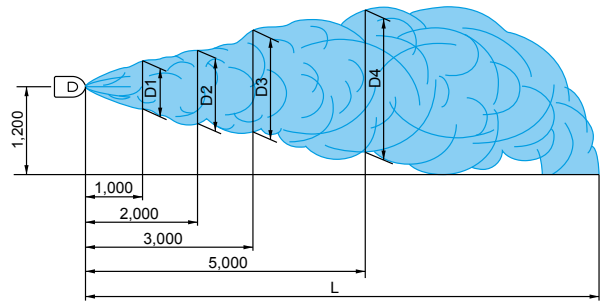

Unit: mm

### ■ Spray angle code: 20

Air consumption code	Air pressure (MPa)	Liquid pressure (MPa)	Spray dimensions (mm)				
			D1	D2	D3	D4	L
37	0.3	0.25-0.35	200	450	750	1,100	9,000
	0.4	0.35-0.45	250	500	850	1,200	10,000
	0.5	0.45-0.55	300	550	900	1,300	10,000
55	0.3	0.25-0.35	250	500	800	1,200	10,000
	0.4	0.35-0.45	300	550	900	1,300	11,000
	0.5	0.45-0.55	350	600	1,000	1,400	11,000
75	0.3	0.25-0.35	300	550	900	1,300	12,000
	0.4	0.35-0.45	350	650	1,000	1,400	13,000
	0.5	0.45-0.55	400	750	1,100	1,500	13,000
110	0.3	0.25-0.35	350	600	1,000	1,400	12,000
	0.4	0.35-0.45	400	700	1,100	1,500	13,000
	0.5	0.45-0.55	450	800	1,200	1,600	13,000
150	0.3	0.25-0.35	400	750	1,100	1,500	13,000
	0.4	0.35-0.45	450	800	1,200	1,600	14,000
	0.5	0.45-0.55	500	850	1,300	1,700	14,000
220	0.3	0.25-0.35	450	800	1,200	1,500	13,000
	0.4	0.35-0.45	500	850	1,250	1,600	14,000
	0.5	0.45-0.55	550	900	1,300	1,700	14,000

Note: The above data were measured with tap water in a laboratory, in windless conditions.

## HOW TO ORDER

Please inquire or order for a specific nozzle using this coding system.

### Flange Type

<Example> GSIM6037II B S316L+1\*1/4T10 SCS13 (L2)

GSIM	<b>60</b>	<b>37</b> II	<b>B</b>	S316L +	<b>1*1/4T10</b>	SCS13	(L2)
	Spray angle code	Air consumption code	Type of length (Total length)	Material of nozzle tip	Flange size	Flange material	Length between the nozzle head and flange
	■60 ■20	■37 ■55 ■75 ■110 ■150 ■220	■A ■B ■C ■D		■1*1/4T10 ■1*1/2T10 ■2T10		
					The minimum flange sizes (Air consumption code: Flange size) 37II, 55II: 1*1/4T10 75II, 110II: 1*1/2T10 150II, 220II: 2T10		

See the drawing and table on page 58 for type of length and length L2.  
For details please ask for our inquiry drawing.

Please send us an inquiry for a different flange size.